

DISCONTINUED ITEM

THIS ITEM HAS BEEN DISCONTINUED AND IS
NO LONGER IN PRODUCTION.
PLEASE CONTACT YOUR LOCAL MONTIGO DEALER
REGARDING MAINTENANCE AND SPARE PARTS AVAILABILITY.

Delray Gasfire

INSTALLATION, OPERATION AND MAINTENANCE MANUAL

MODEL 36DRG

PLEASE READ THIS MANUAL CAREFULLY BEFORE INSTALLING AND OPERATING THE FIREPLACE

THE DELRAY MODEL 36 DRG INSERT IS C.G.A. APPROVED FOR NATURAL GAS AND PROPANE

ALWAYS RETAIN THE MANUAL WITH THE UNIT IN THE EVENT OF A CHANGE OF OWNERSHIP

APPROVED AS A GRAVITY VENTED ROOM HEATER

FOR YOUR SAFETY:

IF YOU SMELL GAS:

- 1.) OPEN WINDOWS
- 2.) DO NOT TOUCH ELECTRICAL SWITCHES
- 3.) EXTINGUISH ANY OPEN FLAME
- 4.) IMMEDIATELY CALL YOUR GAS SUPPLIER

DO NOT STORE OR USE ANY
FLAMMABLE VAPOURS OR LIQUIDS
NEAR THIS OR ANY OTHER GAS-
BURNING APPLIANCE.

FOR INSTALLATION IN ACCORDANCE WITH CANADIAN REQUIREMENTS

CERTIFIED TO STANDARD: CAN/CGA 2.22 - M86 VENTED DECORATIVE APPLIANCE

CAN/CGA 2.17 - M91 HIGH ALTITUDE

CAN/CGA 2.1 - M86 ROOM HEATER



CANADIAN HEATING PRODUCTS INC
13120 - 76TH AVENUE, SURREY B.C. V3W 2V6
PHONE (604) 597-3115 FAX: (604) 597-3096



GENERAL INSTRUCTIONS

NOTE: All gas inspection authorities in Canada require that the installation and maintenance of heaters and accessories shall be accomplished by qualified gas fitters in accordance with the CAN/CGA B149.1 and 2 installation codes and other applicable code requirements specified by the authorities having jurisdiction. The qualified installer shall instruct the user in the safe and correct operation of this appliance and before leaving the installation, the installer shall ensure that the appliance is in safe working order. Do not remove this booklet from installation site.

Installation must conform with local codes or, in the absence of local codes, with the current CAN1 -B149 Installation code.

A FAINT ODOUR AND SLIGHT SMOKING WILL LIKELY BE NOTICED WHEN THE FIREPLACE IS FIRST USED. OPEN A WINDOW UNTIL THE SMOKING STOPS.

**The fireplace is not intended to be used as a substitute for a furnace to heat an entire home.
Use for supplemental heating only.**

The DelRay Gasfire 36DRG is rated at 28,000 BTUH for Natural Gas and 27,000 BTUH for Propane.

1./ COMBUSTION AIR

- A.) In open rooms of normal construction (without storm windows or tightly fitting doors) sufficient combustion air can usually be supplied by infiltration. Ensure that the installation location is adequately ventilated and that the air flow supply is not subject to obstructions.
- B.) Ensure that clearance is maintained around air opening into combustion chamber.

2./ APPLIANCE LOCATION AND CLEARANCES

- A.) Due to high temperatures, the appliance should be located out of traffic areas and away from furniture and draperies ensuring a minimum clearance of 900 mm (36 inches)
- B.) Children and adults should be alerted to the hazards of high surface temperature and should stay away to avoid burns or clothing ignition.
- C.) Young children should be carefully supervised when they are in the same room as the fireplace.
- D.) Clothing or other flammable material should NOT be placed on or near the fireplace.
- E.) Minimum side clearances to combustibles:
**Side Facing: 1" Perpendicular Wall: 3"
Top Facing: 8" Mantle: 18 1/2" {based (See Drawing #1) on 10" shelf depth}**
- F.) The appliance must be installed in a vented solid fuel fireplace with a working flue and constructed of a noncombustible material. (Not for use with air tight units).

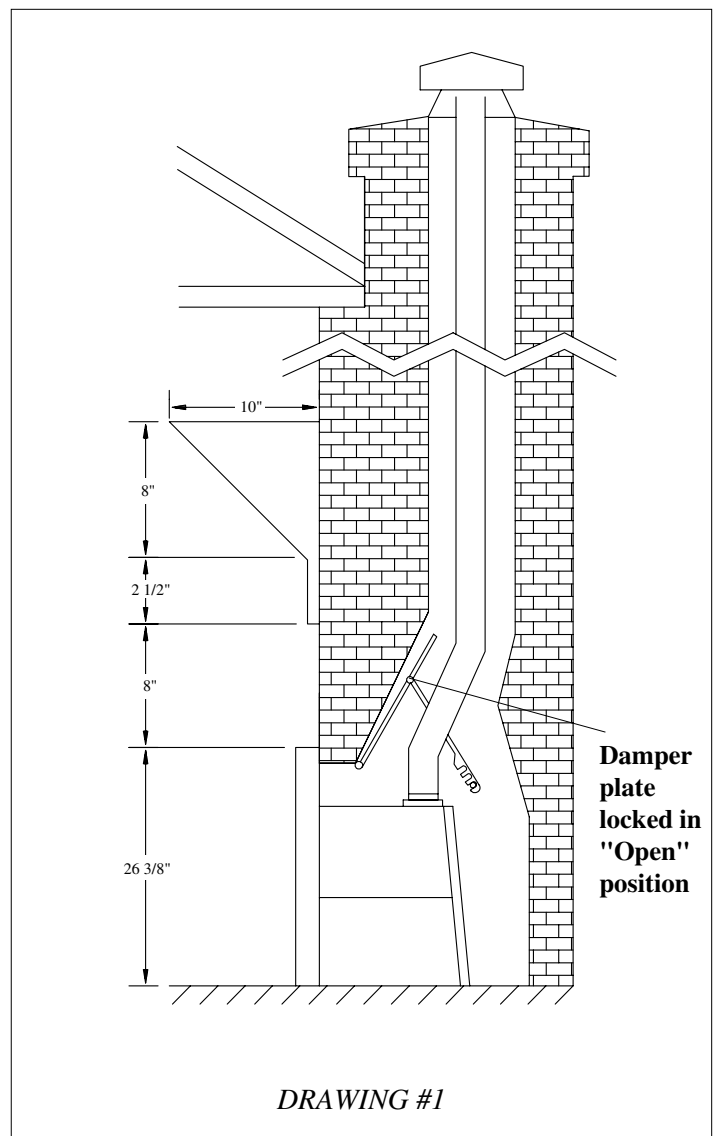

3./ NATURAL GAS AND PROPANE PIPING

A.) All gas piping shall be in accordance with the current CAN/CGA B149.1 and .2 installation codes and installed by a qualified professional gas fitter technician.
 Inlet pressure N/G 7.0 W.C.
 Minimum natural gas inlet pressure 5.0" W.C.
 Manifold pressure 3.5" W.C.

This appliance has been set for 28,000 BTUH at Sea level rating for natural gas and 27,000 BTUH for propane and is CGA certified for altitudes between 0 - 2000 feet without an orifice change and 2000 - 4500 feet with an orifice change. The orifice required for high altitude must be supplied by the manufacturer.

The minimum inlet gas supply pressure permissible is 11" W.C. for propane.

GAS	NATURAL	PROPANE
Manifold Pressure	3.5" W.C.	10.5" W.C.
Minimum Supply Pressure	5.0" W.C.	11" W.C.

B.) Ensure that the gas supply pipe is adequate for the appliance capacity. A 1/8 inch plugged tapping must be provided immediately upstream of the gas supply connection to the appliance for test gauge connection.

After gas line is connected, it is a CAN/CGA B149 code Requirement (Section 8.25.3(e)) that: "each appliance Connection, valve, valve train, shall be checked while under normal pressure with either a liquid solution or leak detection device, to locate any source of leak." Tighten any areas where bubbling appears or leak is detected until Bubbling stops completely. **DO NOT** use a flame of any kind to test for leaks.

4./ VENTING

It is recommended that the chimney be thoroughly cleaned before installation and checked for soundness and general condition.

For proper installation, the use of a 4 inch (100 mm) diameter gas approved chimney liner is needed. This is to provide appropriate draft and avoid excessive corrosion In the combustion chamber and heat exchanger of the appliance.

Before installing the vent system, ensure that the damper plate is locked into the open position and secured to prevent the damper plate from crushing the liner.

(See Drawing #1)

FIREPLACE DIMENSIONS: 2 3/4"
HEIGHT: 21 1/4"
WIDTH: 28"
DEPTH: 13 5/8"

Drawings - #2a, #2b and #2c (with add on)

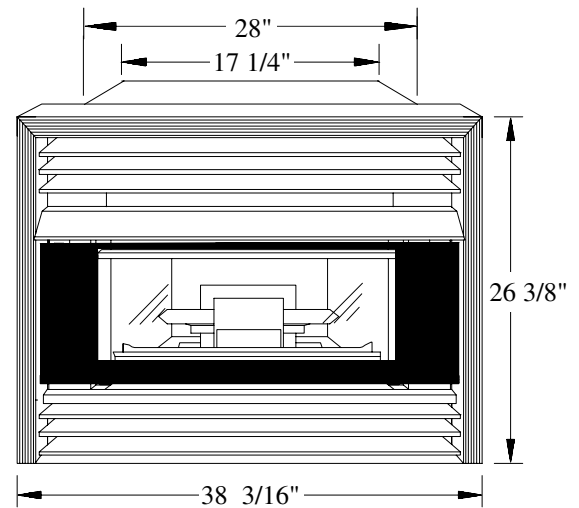
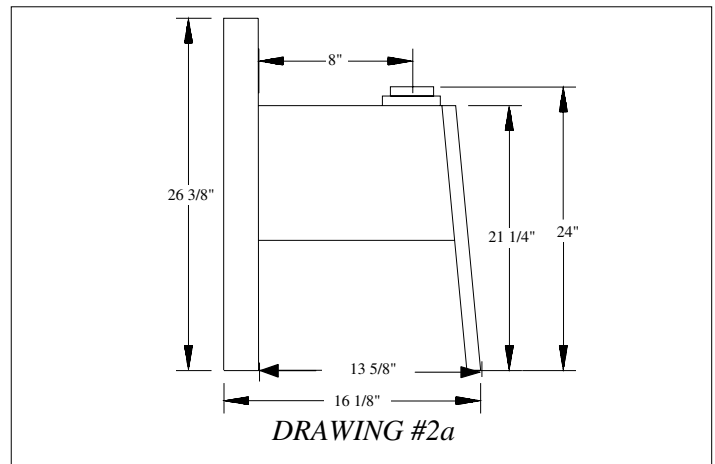

OFFSET BOX

Extends flue collar an additional 3". For applications which require the flue collar to be extended, please order part number 36DRG Offset Box. Installation instructions for this offset box are included with the offset.

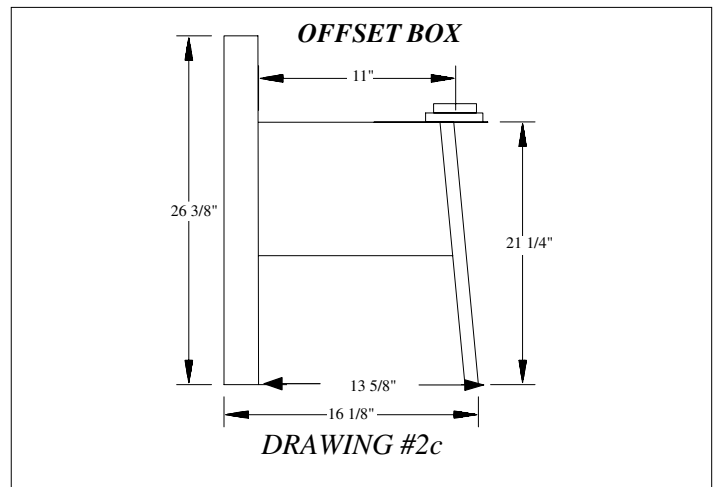

5./ INSERT INSTALLATION

This appliance is to be installed in a masonry or slid fuel fireplace only. (Not for use with air tight units.)

***Ensure that the plastic protective coating on the all brass pieces is removed before lighting the fireplace. Failure to do so will result in permanent damage to the brass.**

The brass louvres can be easily removed from the outer box of the fireplace. We recommend that they are removed to prevent any damage. The louvres are held on with spring loaded pins.

- 1.) Remove the 2 glass panels from the unit to access the heat exchanger {see section on glass panel removal}.
- 2.) Detach burner tray by removing the two screws located on either side of the tray. Pull tray slightly towards the front of the unit and carefully pull Burner out.
- 3.) Unscrew rheostat box and remove
- 4.) Detach decorative hood by removing the screws located on each side.
- 5.) Remove the two screws at the top {left and right side} of the heat exchanger. Pull heat exchanger, including refractory, from the outer shell.
- 6.) Place the outer shell only into the masonry fireplace. (See Drawing #3a)

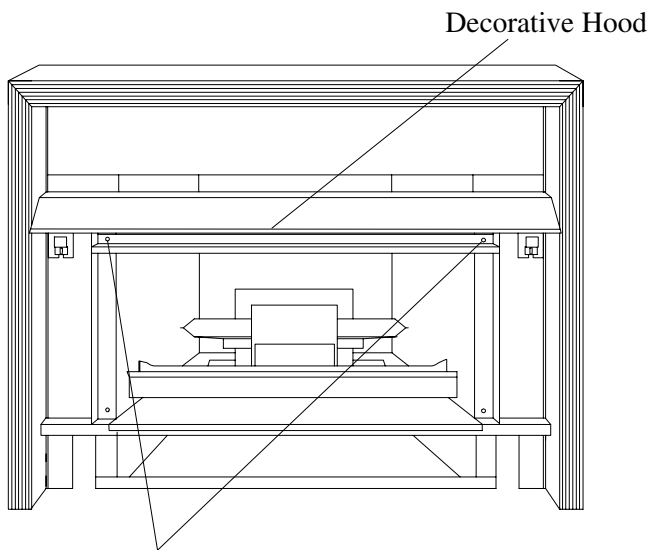

Remove to pull out heat exchanger.

DRAWING #3a

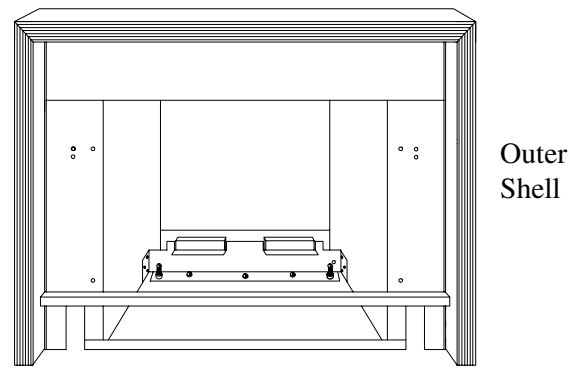

View of Heat Exchanger removed from outer shell

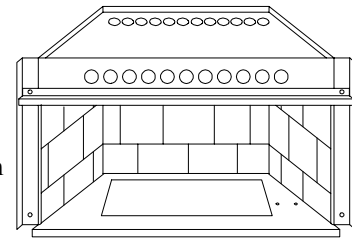

Heat Exchanger

DRAWING #3b

- 7.) To connect the flexible gas liner, detach the draft hood. Drop the flex liner down in to the fireplace shell. Secure the flex liner to the flue collar with a minimum of 2 sheet metal screws.

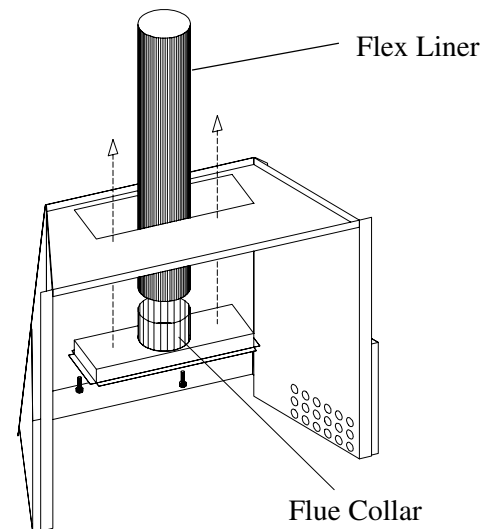

DRAWING #4

8.) Push the draffhood back in to place and re-secure.

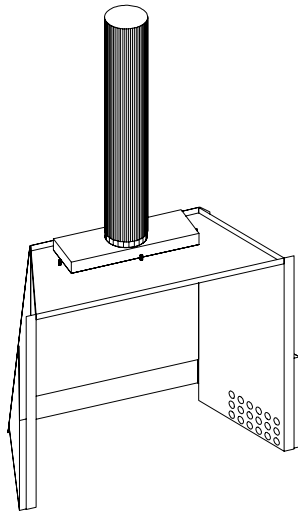

DRAWING #5

9.) Level the unit by adjusting the two hex head machine screws located inside the shell. For easiest access, adjust these screws prior to replacing the heat exchanger. If further adjustments need to be made to level the unit after the heat exchanger has been replaced, locate the levelling bolts behind the gas control. The Piezo ignitor and mounting bracket will have to be removed to reach the bolt on the right hand side. **BE SURE TO MAKE ALL ADJUSTMENTS PRIOR TO CONNECTING THE GAS LINE.**

FAN BRACKET

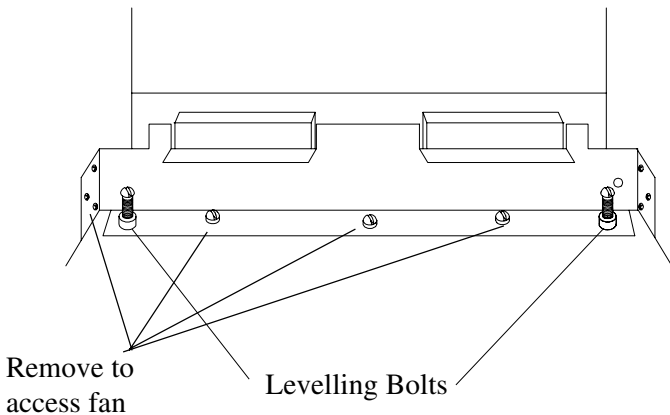

10.) Once the outer shell and heat exchanger have been secured together, re-install the burner tray and rheostat box.

11.) Connect the fan wires to the rheostat and extend the electrical cord along the hearth to wall outlet or direct wire to grounded 120V supply.

RHEOSTAT CONNECTION

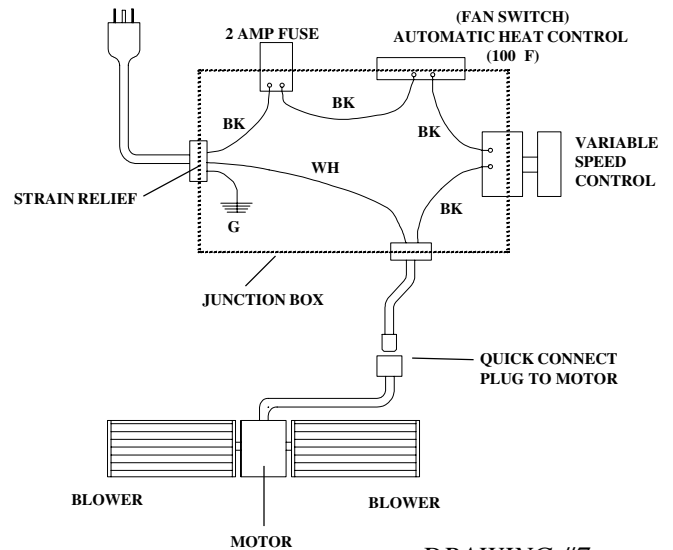

DRAWING #7

12.) Test fan for proper operation.

WARNING: ELECTRICAL GROUNDING INSTRUCTION:

The appliance must be electrically connected and grounded in accordance with local codes or, in the absence of local codes, with the current CSA C22.1 Canadian Electrical Code. The fan is equipped with a three prong (grounding) plug for your protection against shock hazard and should be plugged directly into a properly grounded three prong receptacle. Do not cut or remove the grounding prong from this plug.

SCHEMATIC DIAGRAM

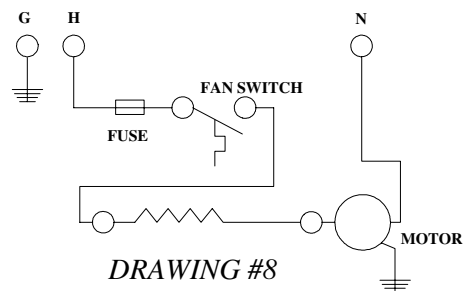

DRAWING #8

NOTE: If any of the original wire as supplied with the appliance must be replaced, it must be replaced with type SEW wire or its equivalent.

COMPONENTS:

- Blower/Motor: Fasco; dual squirrel case blowers
- Fan Switch: T-O-D 60T12; 115 V; 60HZ; 100 F setting; enclosed disk
- Wiring (Internal): Type TEW 105C or equivalent; 18 AWG
- Connectors: Suitable solderless connectors, CSA Listed
- Appliance Cord: Wire Fab; SPT-2; 3 Cond
- Plug: 18 Ga (CSA), moulded plug
- Fuse: 2 Amp; buss type or equivalent
- Pilot Burner & Ignitor: Robertshaw 5SHL2

13.) a) Operating the fan:

The fan speed can be controlled by turning the variable speed control clockwise to slow the fan down and counterclockwise to speed it up.

There is a built-in automatic heat control that will activate when the fireplace has reached (100 F) temperature. The fan will not operate when the fireplace is cold.

b) Removing fan assembly for servicing:

Remove the (3) screws located on each side wing of the fan bracket. Remove the (3) screws located on the base of the bracket. Back out the (2) levelling bolts also located on the box. Remove. (See Drawing #6)

14.) Connect gas to burner using the flexible gas line extension provided with the fireplace.
CAREFULLY TEST TO ENSURE THAT THERE ARE NO LEAKS USING A SOAP SUDS SOLUTION. UNDER NO CONDITION SHALL FLAME OR FIRE BE USED TO LOCATE A GAS LEAK.

15.) Install the log set:

Place log "A" on the log rest at the REAR of the firebox.
Place log "B" on the log rest at the FRONT of the firebox.
Place log "C" on top of logs A & B on the right hand side.
Place log "D" on top of logs A & B on the left hand side.

WARNING: FAILURE TO INSTALL LOGS AS PER INSTRUCTIONS WILL RESULT IN EXCESSIVE SOOTING.

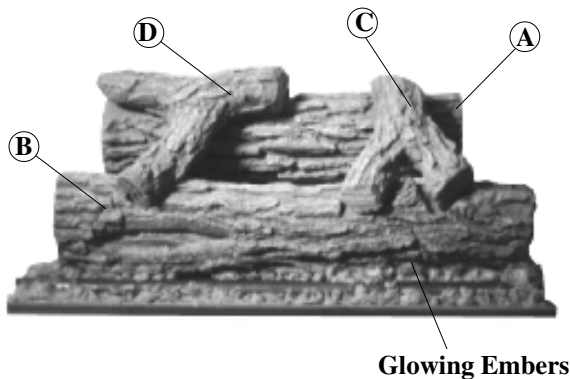

16.) Ember Placement:

Distribute evenly alongside the front burner only. Do not pile material directly on top of burner ports.

CAUTION: IMPROPER PLACEMENT OF EMBERS COULD RESULT IN THE FLAME BEING DIVERTED TOWARDS THE GLASS CAUSING MARKS TO FORM

17.) Glass Placement:

This appliance has two pieces of glass. The smaller sized glass will be placed on the unit first. Place top of glass behind metal strip. Set bottom of glass in place and secure with clips provided.

GLASS REMOVAL / PLACEMENT

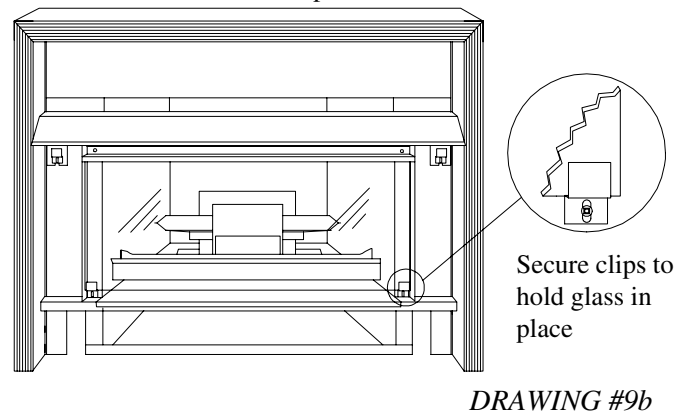
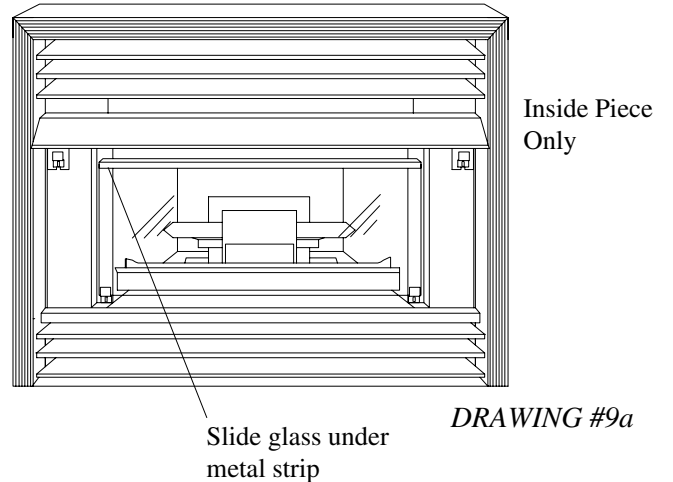

Mount the front piece of glass on the brackets provided underneath the decorative hood piece.

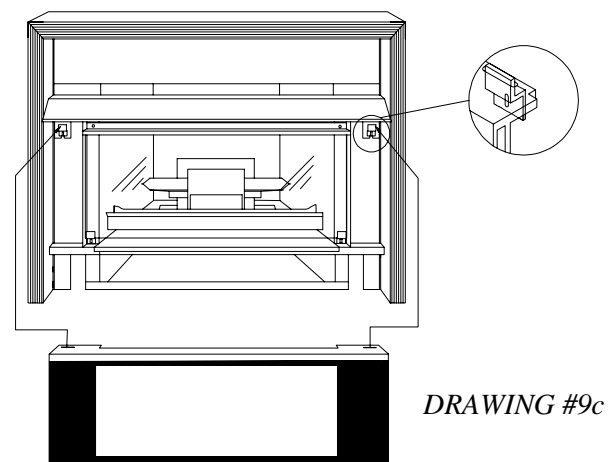

6./ OPERATION

"For safety, this appliance has been equipped with a high limit switch. In the event of over heating, this switch will automatically turn the unit down to pilot. Upon cooling, the main burner will re-light. If this switch is activated, call a qualified service person to inspect the fireplace."

A./ TESTING, ADJUSTING AND CHECKING BURNER AND CONTROLS

Light burner by carefully following instructions for starting given in this manual. Test and adjust all controls under actual operating conditions and in accordance with local installation codes for gas burning appliances.

B./ PILOT BURNER ADJUSTMENT

- 1./ Remove pilot adjustment cap {see figure 10}
- 2./ Adjust pilot key to provide properly sized flame {see figure 11}
- 3./ Replace pilot adjustment cap
- 4./ Leak test with soap solution after installing or servicing with main burner on. Coat pipe and tubing joints etc. with soap solution. Bubbles indicate leaks. Tighten any areas where the bubbles appear until the bubbling stops completely.

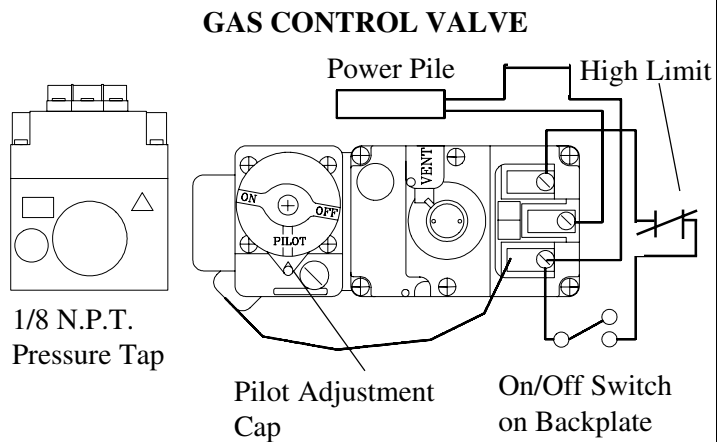

DRAWING #10

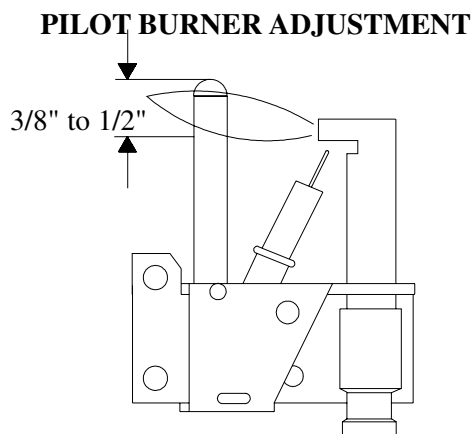

DRAWING #11

C./ LIGHTING INSTRUCTIONS

The gas control valve is located behind the brass trim at the base of the fireplace. Before lighting the pilot, make sure that the gas line is connected and the gas shut-off valve is turned to the ON position.

- a.) Be sure that the ON/OFF switch located on the right side of the backplate is in the "OFF" position
- b.) Partially depress and turn dial on gas control Valve to "OFF" position and wait 5 minutes
- c.) Turn dial to pilot position, depress dial and light pilot using red Piezo ignitor button. Hold dial for 1 minute, then release. If pilot does not remain lit, repeat, allowing a longer time to lapse before releasing dial.
- d.) Once the pilot has been established, turn the ON/OFF switch on the side of the backplate to the "ON" position.
- e.) To light the main burner, turn dial to "ON"
- f.) Main burner function may now be controlled with the ON/OFF switch on the side of the backplate. "OFF" turns the unit back to pilot.
- g.) The "HI/LO" dial located on the valve manually controls the height of the flame on the burner.

D./ SHUT DOWN INSTRUCTIONS:

- a.) Turn knob to the "OFF" position to extinguish main burner and pilot flame

7./ GENERAL MAINTENANCE

Installation and repairs should be done by a qualified service person. It is recommended that the appliance be inspected before use and at least annually by a professional service person. More frequent cleaning may be required due to excessive lint from carpeting, bedding material etc. It is imperative that control compartments, burners and circulating air passageways of the fireplace be kept clean. Any safety guards removed for servicing this appliance must be replaced prior to operating the appliance.

CLEANING PROCEDURE

{GLASS AND BURNER COMPARTMENT}

Periodic cleaning of the glass will be necessary.
Frequency of cleaning will depend on fireplace usage.

- a.) Turn the control knob to the "OFF" position. This will extinguish the flame and allow the unit to cool.
DO NOT ATTEMPT TO CLEAN THE FIREPLACE WHEN IT IS HOT!
- b.) Carefully remove glass pieces. Use caution as glass edges may be sharp
NOTE: IN CASE OF BROKEN GLASS, REPLACEMENT GLASS MUST BE SUPPLIED BY CANADIAN HEATING PRODUCTS INC. OR THE DEALER/DISTRIBUTOR IN YOUR AREA.
- c.) Be sure to use a non-abrasive cleaner on the glass.
- d.) Remove the logs and vacuum thoroughly in and around burner compartment.
NOTE: WHEN CLEANING BURNERS, ALWAYS ENSURE THE GAS HAS BEEN SHUT OFF
- e.) Logs may be cleaned periodically with soap and water
- f.) Prior to replacing the logs, relight the pilot and start the main burner.
 - 1.) Check to see that all burner ports are burning
 - 2.) Check to see that the pilot flame is large enough to engulf the thermopile
 - 3.) Check to see that the main burner ignites instantaneously on all ports when the valve has been turned on
 - 4.) When these checks have been completed, shut down the burner and pilot and reinstall the logs
- g.) Replace the glass
- h.) Check periodically that the vent system is unrestricted and a proper draft is present when the unit is in operation. All vented appliances require a source of fresh air in order to vent properly. Recent trends in home improvement and new tighter construction techniques have contributed to problems with chimney venting properly. If you suspect your fireplace is not venting properly, do not operate the appliance. Seek advice from a qualified professional to determine the cause of the problem and find a solution before restarting the appliance.

- i.) Keep appliance area clear of combustible materials, gasoline and other flammable vapours and liquids.

- j.) **WARNING: DO NOT BURN RUBBISH OF ANY KIND IN THIS APPLIANCE.**

8./ TROUBLE SHOOTING

If the fireplace fails to light or appears to be operating abnormally, do not tamper with it. Contact a licensed service person, the dealer or distributor in your area.

To identify the problem with appliance, you can check the following:

PROBLEM	CORRECTIVE ACTION
Noisy pilot flame	Remove pilot adjuster cap located next to the gas shut off valve. Flame is decreased by turning adjustment screw clockwise.
Pilot won't ignite	Make sure that the wire at the back of the Piezo ignitor button is properly attached. Push the igniter button several times, holding in gas control valve knob. If pilot still will not ignite, remove glass panel and the logs and try lighting pilot with a match. If pilot now lights then the piezo igniter is faulty.
Main burner will not light	Make sure valve control knob is in the "ON" position. Make sure burner switch is on (ON/OFF switch on side of backplate). Check for loose wire connection at the gas valve. NOTE: this is a sensitive millivolt circuit and the pilot or burner will go out if terminals are loose or accidentally grounded.
Flame Cycles	High limit switch is activating. Vent Blocked: Clear flue passage
Severe Downdraft	Check combustion air supply source of energy causing a negative condition within the home.

FOR YOUR SAFETY: IF YOU SMELL GAS, OPEN WINDOWS - DON'T TOUCH ELECTRICAL SWITCHES, EXTINGUISH ANY OPEN FLAME - IMMEDIATELY CALL YOUR GAS SUPPLIER.

NOTE: THIS GUIDE IS MERELY A MEANS OF IDENTIFYING THE PROBLEM AND ITS PROBABLE CAUSE. REPAIRS SHOULD BE DONE BY A QUALIFIED SERVICE PERSON.

ALL PARTS ARE AVAILABLE FROM CANADIAN HEATING PRODUCTS INC. OR YOUR LOCAL DEALER/DISTRIBUTOR.

DELRAY GASFIRE 36 DRG SPARE PARTS

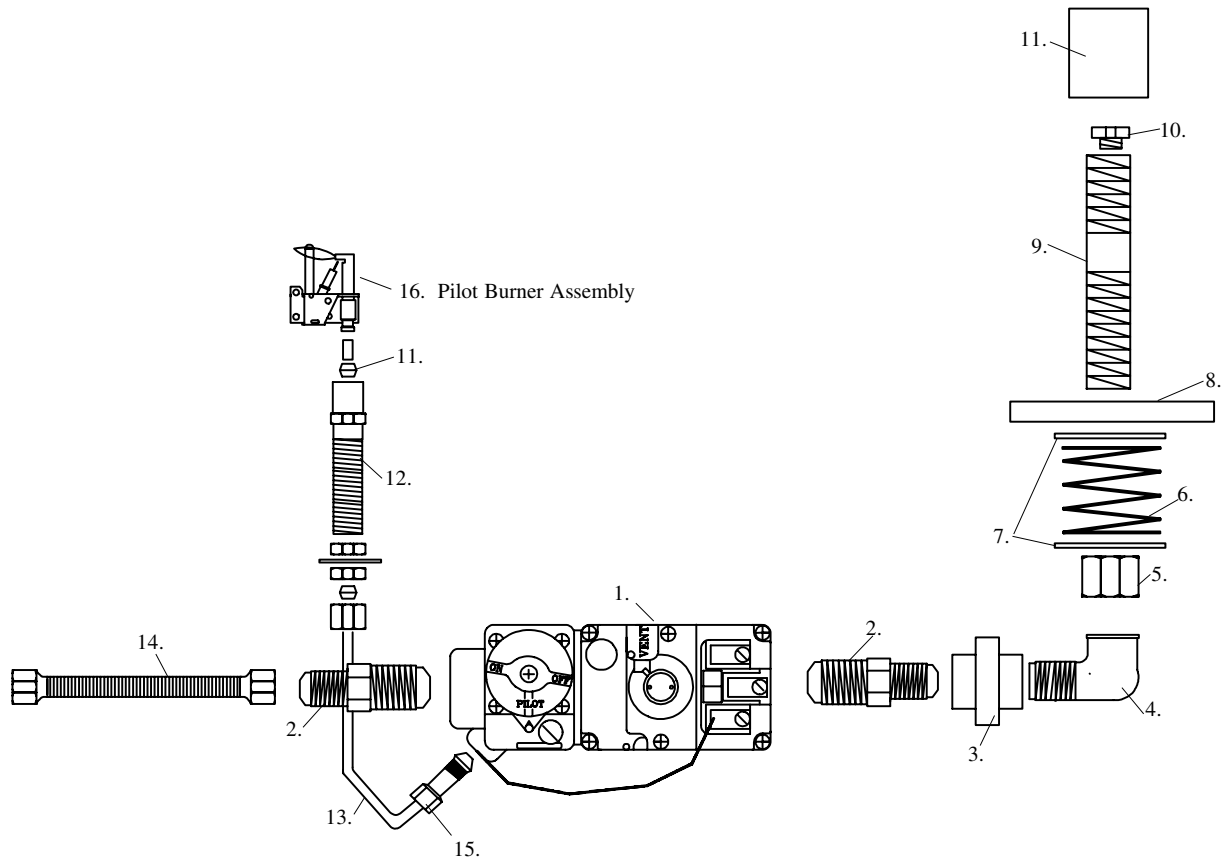

PARTS DESCRIPTION

- | | |
|--|---|
| <ul style="list-style-type: none"> 1. Gas Control Valve 2. 48FF-6 Connector 3. Union 4. 90 degree Steel Elbow 5. Compression Nut 6. 1621410 3500125C CH-1 Compression Spring 7. 3/4" ID Flat Washer 8. Silicon Sponge Seal | <ul style="list-style-type: none"> 9. 3/8" Nipple 10. G09 Brass Orifice 11. Primary Air Mixer 12. 3/8" Nipple 13. CHP-005 Bulk Head Union 14. Flexible Metal Connector 15. 81-4N Pilot Nut 16. Robertshaw 5SHL2 |
|--|---|

DELRAY GASFIRE 36DRG GAS FIREPLACE WARRANTY

THE WARRANTY

The Companies warrants the Montigo Gas Appliance to be free from defects in materials and workmanship at the time of manufacture. On the Montigo, there is a ten-year warranty on the firebox and its components, a five-year warranty on the main burner, pilot burner and a one-year warranty on the gas control valve and glass doors.

REMEDY AND EXCLUSIONS

The coverage of this Warranty is limited to all components of the Gas Appliance manufactured by The Companies.

This Warranty only covers Montigo Gas Appliances installed in the United States or Canada.

If the components of the Gas Appliance covered by this Warranty are found to be defective within the time frame stated (see The Companies right of investigation outlined below). The Companies will, at its option, replace or repair defective components of the Gas Appliance manufactured by The Companies at no charge, and will also pay for reasonable labour costs incurred in replacing or repairing components. If repair or replacement is not commercially practical, The Companies will, at its option, refund the purchase price of the Montigo Gas Appliance.

This Warranty covers only parts and labour as provided above. In no case shall The Companies be responsible for materials, components, or construction which are not manufactured or supplied by The Companies, or for the labour necessary to install, repair or remove such materials, components or construction. All replacement or repair components will be shipped F.O.B. the nearest The Companies factory.

QUALIFICATIONS TO THE WARRANTY

The Gas Appliance Warranty outlined above is further subject to the following qualifications:

(1) The Gas Appliance must be installed in accordance with The Companies installation instructions and local building codes. The Warranty on this Montigo Gas Appliance covers only the component parts manufactured by The Companies. The use of components manufactured by others with this Montigo Gas Appliance could create serious safety hazards, may result in the denial of certification by recognized national safety agencies, and could be in violation of local building codes. This warranty does not cover any damages occurring from the use of any components not manufactured or supplied by The Companies

(2) The Montigo Gas Appliance must be subjected to normal use. The Gas Appliances are designed to burn gas only. Burning conventional fireplace fuels such as wood, coal or any other solid fuel will cause damage to the Gas Appliance, will produce excessive temperatures and will result in a fire hazard.

LIMITATIONS ON LIABILITY

It is expressly agreed and understood that The Companies sole obligation, and purchaser's exclusive remedy under this Warranty, under any other warranty, expressed or implied, or in contract, tort or otherwise, shall be limited to replacement, repair, or refund, as specified above.

In no event shall The Companies be responsible for any incidental or consequential damages caused by defects in its products, whether such damage occurs or is discovered before or after replacement or repair, and whether or not such damage is caused by The Companies negligence. Some states do not allow the exclusion or limitation of incidental or consequential damages, so the above limitation or exclusion may not apply to you. The duration of any implied warranty with respect to this Montigo Wall Furnace is limited to the duration of the foregoing warranty. Some states do not allow limitation on how long an implied warranty lasts, so the above may not apply to you.

INVESTIGATION OF CLAIMS AGAINST WARRANTY

The Companies reserves the right to investigate any and all claims against this Warranty and to decide upon method of settlement.

THE COMPANIES ARE NOT RESPONSIBLE FOR WORK DONE WITHOUT WRITTEN CONSENT

The Companies shall in no event be responsible for any warranty work done without first obtaining The Companies written consent.

DEALERS HAVE NO AUTHORITY TO ALTER THIS WARRANTY

The Companies employees and dealers have no authority to make any warranties nor to authorize any remedies in addition to or inconsistent with those stated above.

HOW TO REGISTER A CLAIM AGAINST WARRANTY

In order for any claim under this Warranty to be valid, The Companies must be notified of the claimed defect in writing or by telephone, as soon as reasonably possible after the defect is discovered. Claims against this Warranty in writing should include the date of installation, and a description of the defect.

OTHER RIGHTS

This Warranty gives you specific legal rights, and you may also have other rights which vary from state to state.

NOTE: The Companies as stated above refer to - Canadian Heating Products Inc. and/or Montigo Del Ray Corp.

Canadian Heating Products Inc. and/or Montigo DelRay Corp. reserves the right to make changes at any time, without notice, in design, materials, specifications, prices and also to discontinue colors, styles and products.



MONTIGO DEL RAY CORP.
6925 Salashan Parkway, Ferndale, WA 98248
Tel: (206) 366-3507 Fax: (206) 366-1054



CANADIAN HEATING PRODUCTS INC.
13120 76th Avenue, Surrey, B.C. Canada V3W 2V6
Telephone (604) 597-3115
Fax (604) 597-3096