

MONTIGO® CFPO-RD-36-SB-DL-MS Firepit Round

TECHNICAL SPECIFICATION

This Montigo commercial firepit and its associated components are part of a custom engineered system. All systems are tested and certified to current ANSI Standards with CSA International US and Canada.

Please contact Montigo to confirm if your installation requirements are within the parameters of these standard specifications.

Unit should be located in an exterior, well-ventilated location. If located under a roof or overhang, limitations may apply (please verify). If located in an unprotected area, unit should be covered when not in use.

Waiver required for mesh screen enclosure.

OVERVIEW

Burner Area: 36" Dia.

Integrated drink ledge

Protective mesh screen enclosure

TYPICAL INTAKE

Intake Size: 13 1/2" sq.in. min.

Intake Location: Bottom

TYPICAL EXHAUST

Outdoor appliance, no dedicated vent

GAS

Rating Input: Estimated 60,000 BTU/hr

Minimum Inlet Pressure: 5.5" w.c. Natural Gas / 11" w.c. Propane

Gas System: 1/2" NPT bottom, Hot Surface Ignition, Smart Valve

Concealed modular burner with plume flame

CONSTRUCTION

Satin galvanized (black), delivered finished or can be clad; supplied locally by others

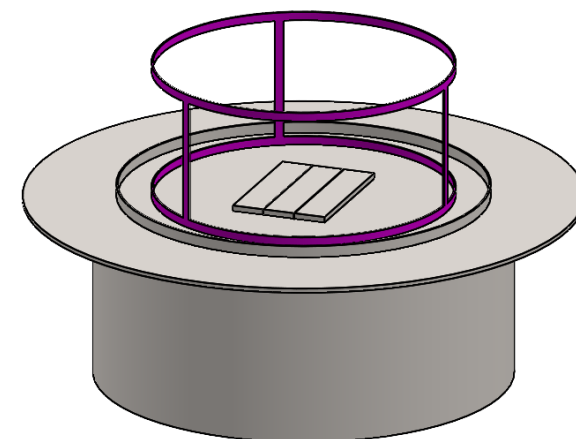

ELECTRICAL

Standalone NEMA weatherproof box with built-in on/off switch mounted within 50' -150' of firepit near 120 VAC 5 AMP exterior outlet

Box includes short whip and three prong plug

BURNER MEDIA

Glass media

Optional: Driftwood logs, speckled stones

TESTING STANDARDS

ANSI Z21.97-2017/CSA 2.41-2017

For further information visit:
www.montigo.com/commercial-fireplaces
Contact: quotes@montigo.com



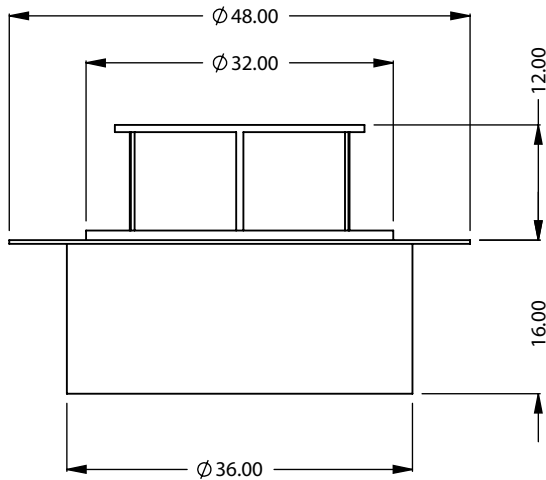
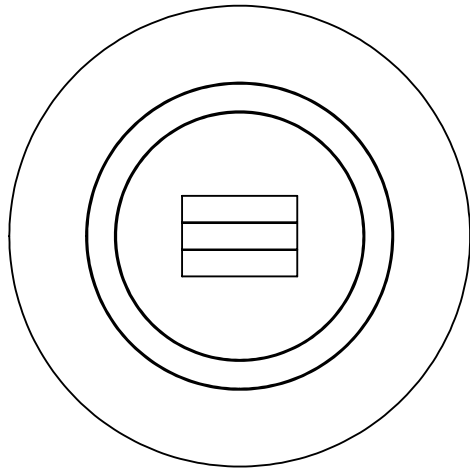

MESH SCREEN

3/8" DRINK LEDGE THICKNESS

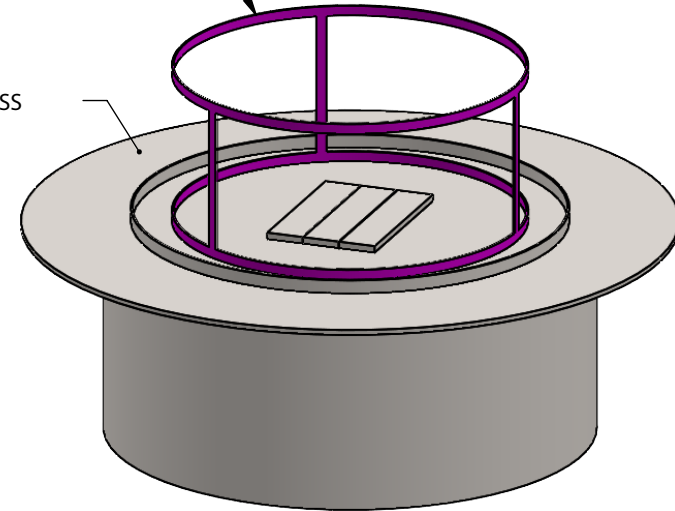

CFPO-RD-36-SB-DL-MS
 Round Firepit
Bottom Intake

**PRELIMINARY
 DRAWING ONLY** 

EXAMPLE CONFIGURATION	UNLESS OTHERWISE SPECIFIED	DATE
MONTIGO COMMERCIAL FIREPLACES ARE CUSTOM BUILT FOR EACH PROJECT. THIS DRAWING IS FOR REFERENCE ONLY. FLUE AND AIR INTAKE SIZES ARE SUBJECT TO CHANGE DEPENDING ON VENT RUN.	DIMENSIONS ARE IN INCHES TOLERANCES: FRACTIONAL $\pm 1/8"$	4/25/2023

MONTIGO
 the art of **fireplaces**
 www.montigo.com

MONTIGO® CFPO-RD-36-SB-DL Firepit Round

TECHNICAL SPECIFICATION

This Montigo commercial firepit and its associated components are part of a custom engineered system. All systems are tested and certified to current ANSI Standards with CSA International US and Canada.

Please contact Montigo to confirm if your installation requirements are within the parameters of these standard specifications.

Unit should be located in an exterior, well-ventilated location. If located under a roof or overhang, limitations may apply (please verify). If located in an unprotected area, unit should be covered when not in use.

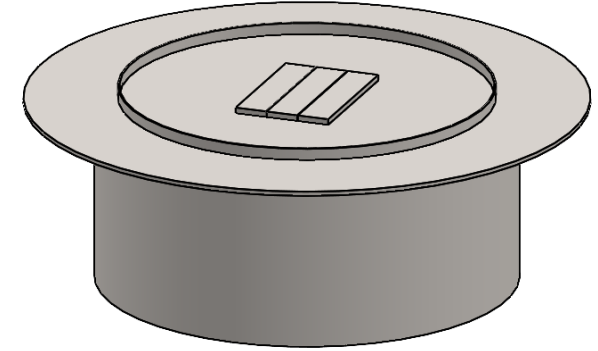

OVERVIEW

Burner Area: 36" Dia.

Integrated drink ledge

OPTIONS

Single or double protective glass†

Note: Unit dimensions will increase when single or double glass is requested. Please inquire as to actual size.

TYPICAL INTAKE

Intake Size: 13 ½" sq.in. min.

Intake Location: Bottom

TYPICAL EXHAUST

Outdoor appliance, no dedicated vent

GAS

Rating Input: Estimated 60,000 BTU/hr

Minimum Inlet Pressure: 5.5" w.c. Natural Gas / 11" w.c. Propane

Gas System: ½" NPT bottom, Hot Surface Ignition, Smart Valve

Concealed modular burner with plume flame

CONSTRUCTION

Satin galvanized (black), delivered finished or can be clad; supplied locally by others

ELECTRICAL

Standalone NEMA weatherproof box with built-in on/off switch mounted within 50' -150' of firepit near 120 VAC 5 AMP exterior outlet

Box includes short whip and three prong plug

BURNER MEDIA

Glass media

Optional: Driftwood logs, speckled stones

TESTING STANDARDS

ANSI Z21.97-2017/CSA 2.41-2017

† May be available, please inquire on your specific project, waiver required

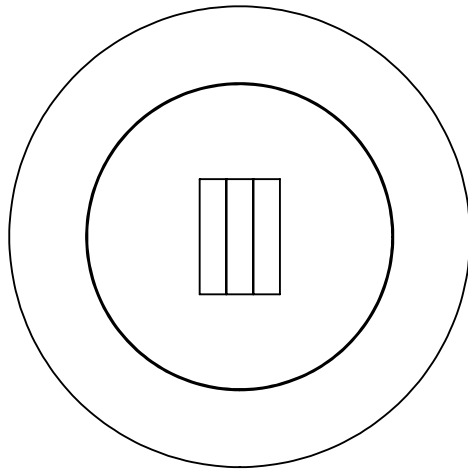

DRINK LEDGE THICKNESS 3/8"

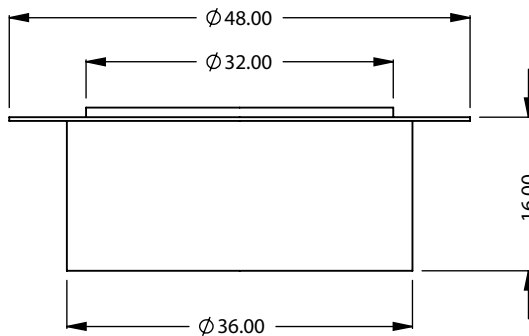
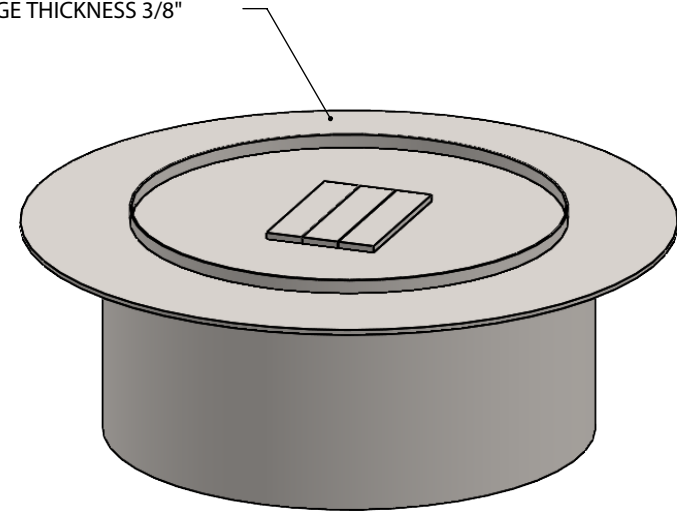

CFPO-RD-36-SB-DL
 Round Firepit
Bottom Intake

**PRELIMINARY
 DRAWING ONLY** 

EXAMPLE CONFIGURATION	UNLESS OTHERWISE SPECIFIED	DATE
MONTIGO COMMERCIAL FIREPLACES ARE CUSTOM BUILT FOR EACH PROJECT. THIS DRAWING IS FOR REFERENCE ONLY. FLUE AND AIR INTAKE SIZES ARE SUBJECT TO CHANGE DEPENDING ON VENT RUN.	DIMENSIONS ARE IN INCHES TOLERANCES: FRACTIONAL $\pm 1/8"$	4/25/2023

MONTIGO
 the art of **fireplaces**
 www.montigo.com

MONTIGO® CFPO-RD-36-TB-DL-MS Firepit Round

TECHNICAL SPECIFICATION

This Montigo commercial firepit and its associated components are part of a custom engineered system. All systems are tested and certified to current ANSI Standards with CSA International US and Canada.

Please contact Montigo to confirm if your installation requirements are within the parameters of these standard specifications.

Unit should be located in an exterior, well-ventilated location. If located under a roof or overhang, limitations may apply (please verify). If located in an unprotected area, unit should be covered when not in use.

Waiver required for mesh screen enclosure.

OVERVIEW

Burner Area: 36" Dia.

Integrated drink ledge

Protective mesh screen enclosure

TYPICAL INTAKE

Intake Size: 13 1/2" sq.in. min.

Intake Location: Bottom

TYPICAL EXHAUST

Outdoor appliance, no dedicated vent

GAS

Rating Input: Estimated 60,000 BTU/hr

Minimum Inlet Pressure: 5.5" w.c. Natural Gas / 11" w.c. Propane

Gas System: 1/2" NPT bottom, Hot Surface Ignition, Smart Valve

Concealed modular burner with plume flame

CONSTRUCTION

Satin galvanized (black), delivered finished or can be clad; supplied locally by others

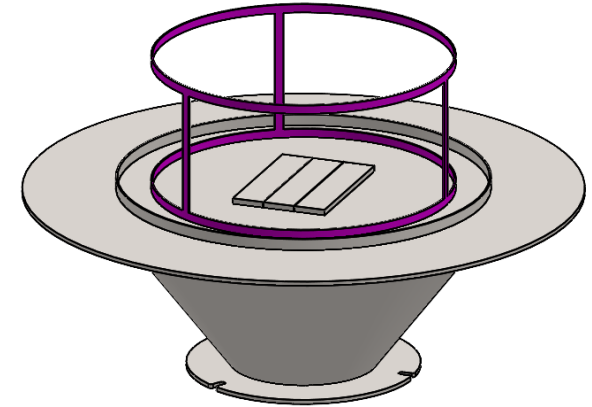

ELECTRICAL

Standalone NEMA weatherproof box with built-in on/off switch mounted within 50' -150' of firepit near 120 VAC 5 AMP exterior outlet

Box includes short whip and three prong plug

BURNER MEDIA

Glass media

Optional: Driftwood logs, speckled stones

TESTING STANDARDS

ANSI Z21.97-2017/CSA 2.41-2017

For further information visit:
www.montigo.com/commercial-fireplaces
Contact: quotes@montigo.com



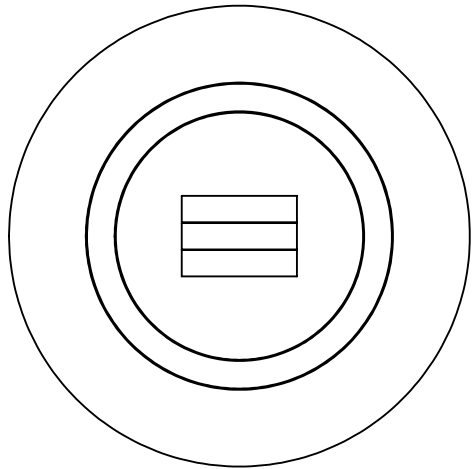

MESH SCREEN

3/8" DRINK LEDGE THICKNESS

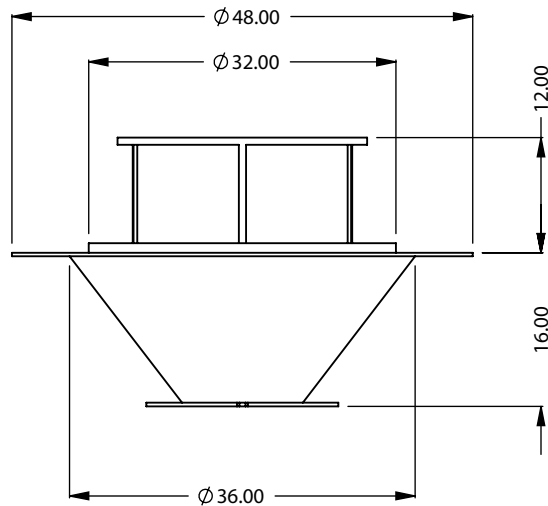
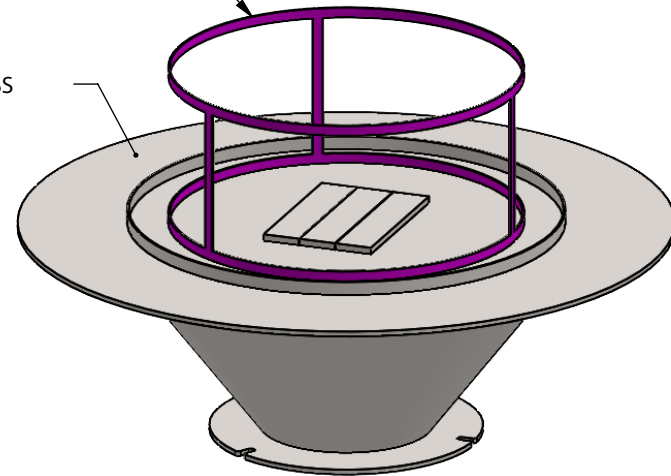

CFPO-RD-36-TB-DL-MS
 Round Firepit
Bottom Intake

**PRELIMINARY
 DRAWING ONLY**

EXAMPLE CONFIGURATION	UNLESS OTHERWISE SPECIFIED	DATE
MONTIGO COMMERCIAL FIREPLACES ARE CUSTOM BUILT FOR EACH PROJECT. THIS DRAWING IS FOR REFERENCE ONLY. FLUE AND AIR INTAKE SIZES ARE SUBJECT TO CHANGE DEPENDING ON VENT RUN.	DIMENSIONS ARE IN INCHES TOLERANCES: FRACTIONAL $\pm 1/8"$	4/25/2023

MONTIGO
 the art of **fireplaces**
www.montigo.com

TECHNICAL SPECIFICATION

This Montigo commercial firepit and its associated components are part of a custom engineered system. All systems are tested and certified to current ANSI Standards with CSA International US and Canada.

Please contact Montigo to confirm if your installation requirements are within the parameters of these standard specifications.

Unit should be located in an exterior, well-ventilated location. If located under a roof or overhang, limitations may apply (please verify). If located in an unprotected area, unit should be covered when not in use.

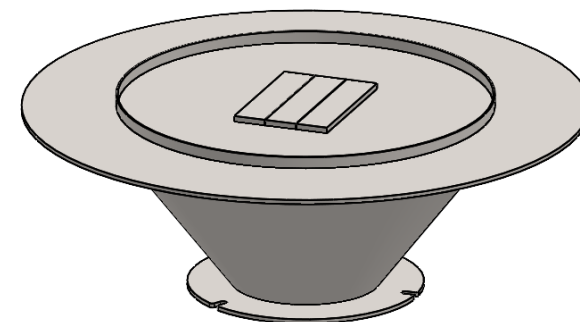

OVERVIEW

Burner Area: 36" Dia.

Integrated drink ledge

OPTIONS

Single or double protective glass†

Note: Unit dimensions will increase when single or double glass is requested. Please inquire as to actual size.

TYPICAL INTAKE

Intake Size: 13 ½" sq.in. min.

Intake Location: Bottom

TYPICAL EXHAUST

Outdoor appliance, no dedicated vent

GAS

Rating Input: Estimated 60,000 BTU/hr

Minimum Inlet Pressure: 5.5" w.c. Natural Gas / 11" w.c. Propane

Gas System: ½" NPT bottom, Hot Surface Ignition, Smart Valve

Concealed modular burner with plume flame

CONSTRUCTION

Satin galvanized (black), delivered finished or can be clad; supplied locally by others

ELECTRICAL

Standalone NEMA weatherproof box with built-in on/off switch mounted within 50' -150' of firepit near 120 VAC 5 AMP exterior outlet

Box includes short whip and three prong plug

BURNER MEDIA

Glass media

Optional: Driftwood logs, speckled stones

TESTING STANDARDS

ANSI Z21.97-2017/CSA 2.41-2017

† May be available, please inquire on your specific project, waiver required

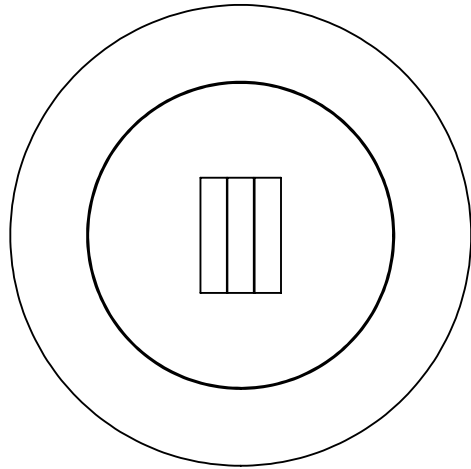

3/8" DRINK LEDGE THICKNESS

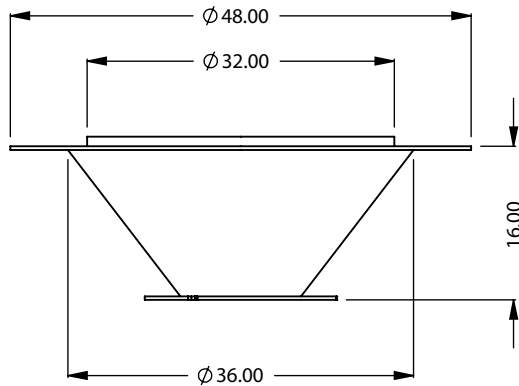
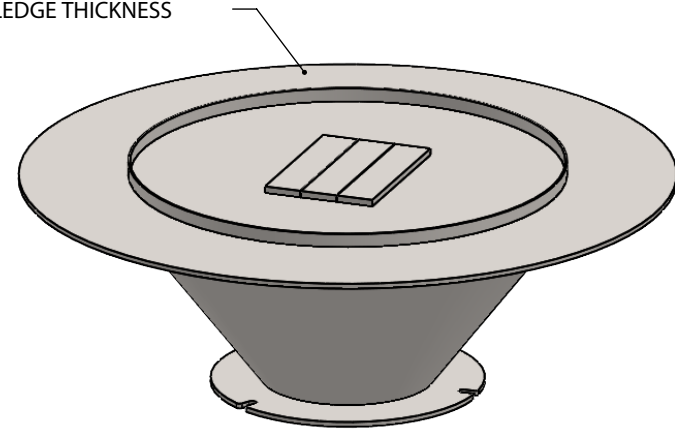

CFPO-RD-36-TB-DL
 Round Firepit
Bottom Intake

**PRELIMINARY
 DRAWING ONLY** 

EXAMPLE CONFIGURATION	UNLESS OTHERWISE SPECIFIED	DATE
MONTIGO COMMERCIAL FIREPLACES ARE CUSTOM BUILT FOR EACH PROJECT. THIS DRAWING IS FOR REFERENCE ONLY. FLUE AND AIR INTAKE SIZES ARE SUBJECT TO CHANGE DEPENDING ON VENT RUN.	DIMENSIONS ARE IN INCHES TOLERANCES: FRACTIONAL $\pm 1/8"$	4/25/2023

MONTIGO
 the art of **fireplaces**
 www.montigo.com

MONTIGO® CFPO-RD-48-SB-DL-MS Firepit Round

TECHNICAL SPECIFICATION

This Montigo commercial firepit and its associated components are part of a custom engineered system. All systems are tested and certified to current ANSI Standards with CSA International US and Canada.

Please contact Montigo to confirm if your installation requirements are within the parameters of these standard specifications.

Unit should be located in an exterior, well-ventilated location. If located under a roof or overhang, limitations may apply (please verify). If located in an unprotected area, unit should be covered when not in use.

Waiver required for mesh screen enclosure.

OVERVIEW

Burner Area: 48" Dia.

Integrated drink ledge

Protective mesh screen enclosure

TYPICAL INTAKE

Intake Size: 17" sq.in. min.

Intake Location: Bottom

TYPICAL EXHAUST

Outdoor appliance, no dedicated vent

GAS

Rating Input: Estimated 90,000 BTU/hr

Minimum Inlet Pressure: 5.5" w.c. Natural Gas / 11" w.c. Propane

Gas System: ½" NPT bottom, Hot Surface Ignition, Smart Valve

Concealed modular burner with plume flame

CONSTRUCTION

Satin galvanized (black), delivered finished or can be clad; supplied locally by others

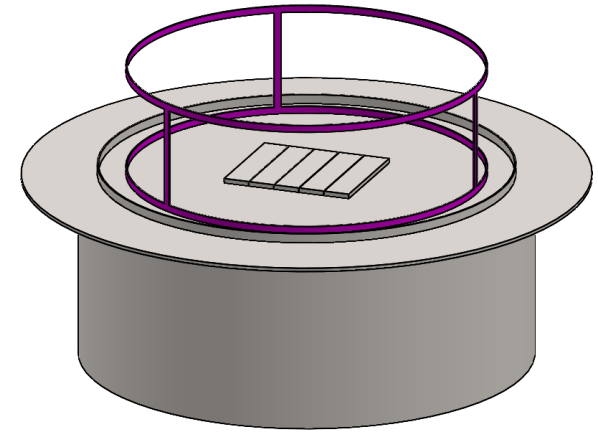

ELECTRICAL

Standalone NEMA weatherproof box with built-in on/off switch mounted within 50' -150' of firepit near 120 VAC 5 AMP exterior outlet

Box includes short whip and three prong plug

BURNER MEDIA

Glass media

Optional: Driftwood logs, speckled stones

TESTING STANDARDS

ANSI Z21.97-2017/CSA 2.41-2017

For further information visit:
www.montigo.com/commercial-fireplaces
Contact: quotes@montigo.com



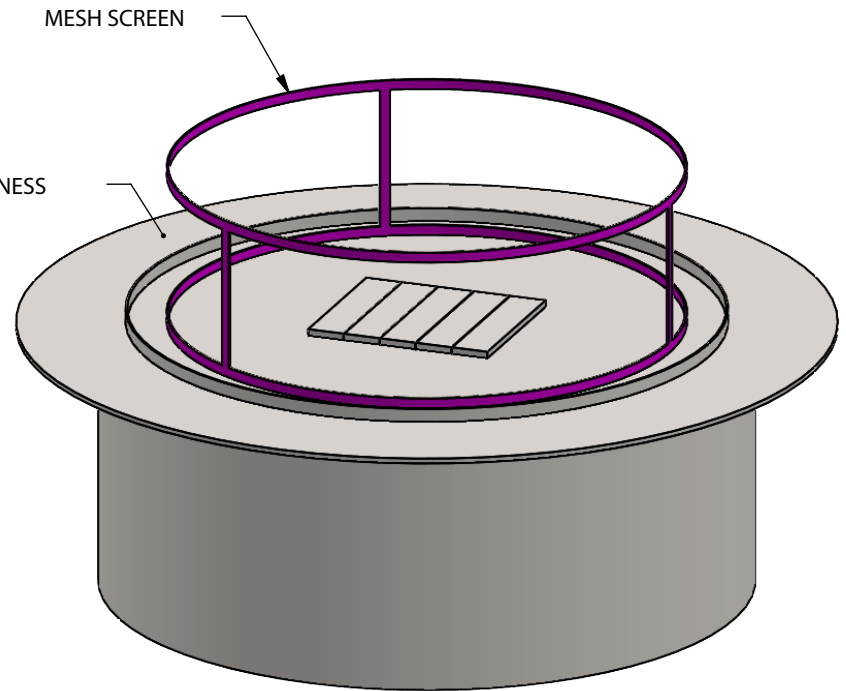
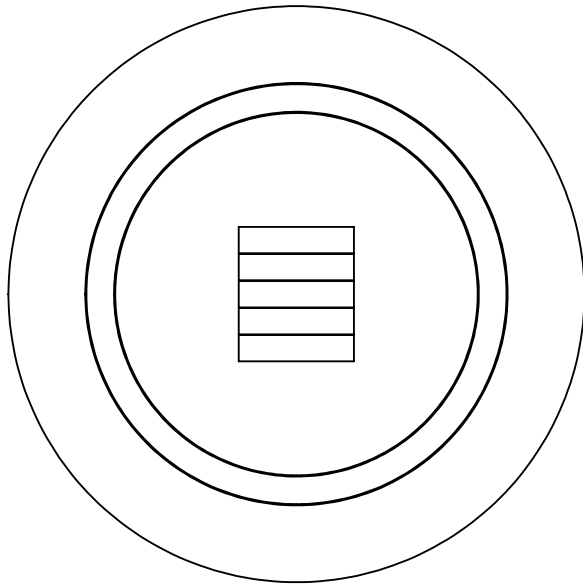

3/8" DRINK LEDGE THICKNESS

MESH SCREEN

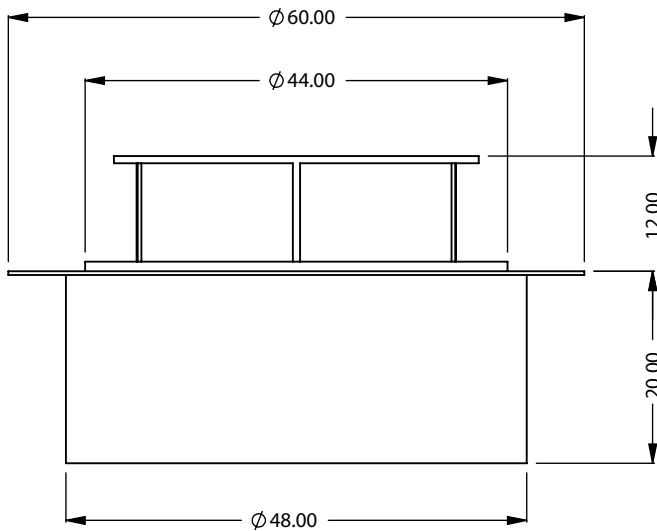

CFPO-RD-48-SB-DL-MS
 Round Firepit
Bottom Intake

**PRELIMINARY
 DRAWING ONLY**

EXAMPLE CONFIGURATION	UNLESS OTHERWISE SPECIFIED	DATE
MONTIGO COMMERCIAL FIREPLACES ARE CUSTOM BUILT FOR EACH PROJECT. THIS DRAWING IS FOR REFERENCE ONLY. FLUE AND AIR INTAKE SIZES ARE SUBJECT TO CHANGE DEPENDING ON VENT RUN.	DIMENSIONS ARE IN INCHES TOLERANCES: FRACTIONAL $\pm 1/8"$	4/25/2023

MONTIGO
 the art of **fireplaces**
 www.montigo.com

MONTIGO® CFPO-RD-48-SB-DL Firepit Round

TECHNICAL SPECIFICATION

This Montigo commercial firepit and its associated components are part of a custom engineered system. All systems are tested and certified to current ANSI Standards with CSA International US and Canada.

Please contact Montigo to confirm if your installation requirements are within the parameters of these standard specifications.

Unit should be located in an exterior, well-ventilated location. If located under a roof or overhang, limitations may apply (please verify). If located in an unprotected area, unit should be covered when not in use.

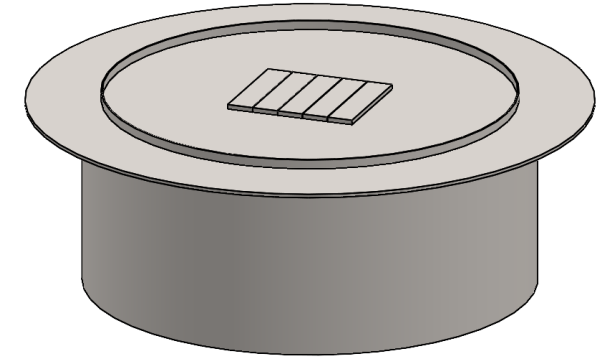

OVERVIEW

Burner Area: 48" Dia.

Integrated drink ledge

OPTIONS

Single or double protective glass†

Note: Unit dimensions will increase when single or double glass is requested. Please inquire as to actual size.

TYPICAL INTAKE

Intake Size: 17" sq.in. min.

Intake Location: Bottom

TYPICAL EXHAUST

Outdoor appliance, no dedicated vent

GAS

Rating Input: Estimated 90,000 BTU/hr

Minimum Inlet Pressure: 5.5" w.c. Natural Gas / 11" w.c. Propane

Gas System: ½" NPT bottom, Hot Surface Ignition, Smart Valve

Concealed modular burner with plume flame

CONSTRUCTION

Satin galvanized (black), delivered finished or can be clad; supplied locally by others

ELECTRICAL

Standalone NEMA weatherproof box with built-in on/off switch mounted within 50' -150' of firepit near 120 VAC 5 AMP exterior outlet

Box includes short whip and three prong plug

BURNER MEDIA

Glass media

Optional: Driftwood logs, speckled stones

TESTING STANDARDS

ANSI Z21.97-2017/CSA 2.41-2017

† May be available, please inquire on your specific project, waiver required

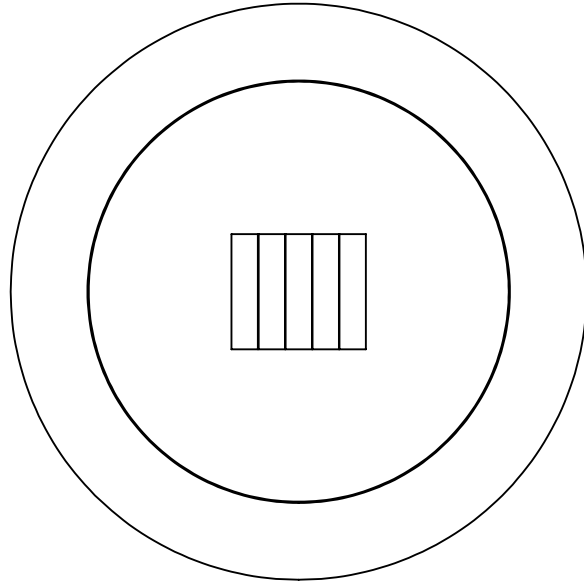

DRINK LEDGE THICKNESS 3/8"

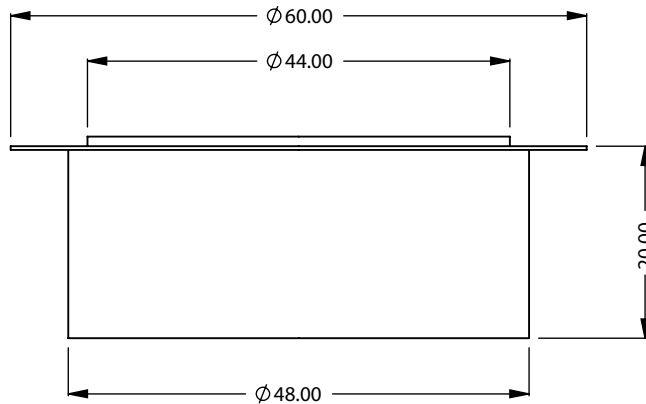
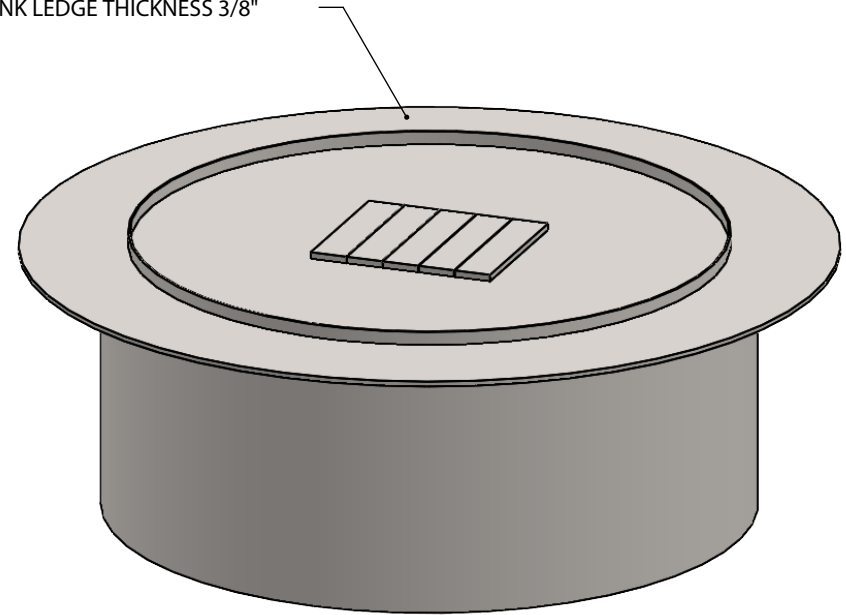

CFPO-RD-48-SB-DL
 Round Firepit
Bottom Intake

**PRELIMINARY
 DRAWING ONLY** 

EXAMPLE CONFIGURATION

MONTIGO COMMERCIAL FIREPLACES ARE CUSTOM BUILT FOR EACH PROJECT. THIS DRAWING IS FOR REFERENCE ONLY.

FLUE AND AIR INTAKE SIZES ARE SUBJECT TO CHANGE DEPENDING ON VENT RUN.

UNLESS OTHERWISE SPECIFIED

DIMENSIONS ARE IN INCHES
 TOLERANCES: FRACTIONAL $\pm 1/8"$

DATE

4/25/2023

MONTIGO
 the art of **fireplaces**

www.montigo.com

MONTIGO® CFPO-RD-48-TB-DL-MS Firepit Round

TECHNICAL SPECIFICATION

This Montigo commercial firepit and its associated components are part of a custom engineered system. All systems are tested and certified to current ANSI Standards with CSA International US and Canada.

Please contact Montigo to confirm if your installation requirements are within the parameters of these standard specifications.

Unit should be located in an exterior, well-ventilated location. If located under a roof or overhang, limitations may apply (please verify). If located in an unprotected area, unit should be covered when not in use.

Waiver required for mesh screen enclosure.

OVERVIEW

Burner Area: 48" Dia.

Integrated drink ledge

Protective mesh screen enclosure

TYPICAL INTAKE

Intake Size: 17" sq.in. min.

Intake Location: Bottom

TYPICAL EXHAUST

Outdoor appliance, no dedicated vent

GAS

Rating Input: Estimated 90,000 BTU/hr

Minimum Inlet Pressure: 5.5" w.c. Natural Gas / 11" w.c. Propane

Gas System: ½" NPT bottom, Hot Surface Ignition, Smart Valve

Concealed modular burner with plume flame

CONSTRUCTION

Satin galvanized (black), delivered finished or can be clad; supplied locally by others

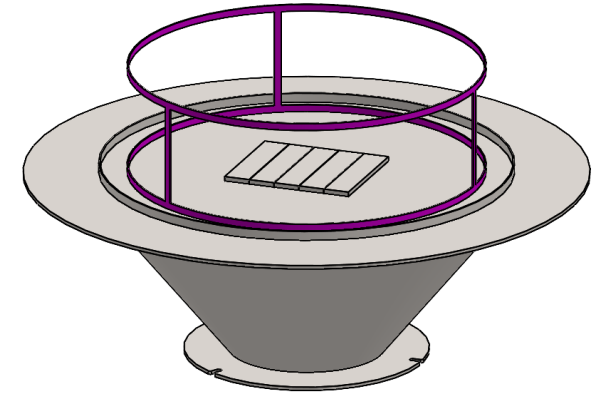

ELECTRICAL

Standalone NEMA weatherproof box with built-in on/off switch mounted within 50' -150' of firepit near 120 VAC 5 AMP exterior outlet

Box includes short whip and three prong plug

BURNER MEDIA

Glass media

Optional: Driftwood logs, speckled stones

TESTING STANDARDS

ANSI Z21.97-2017/CSA 2.41-2017

For further information visit:
www.montigo.com/commercial-fireplaces
Contact: quotes@montigo.com



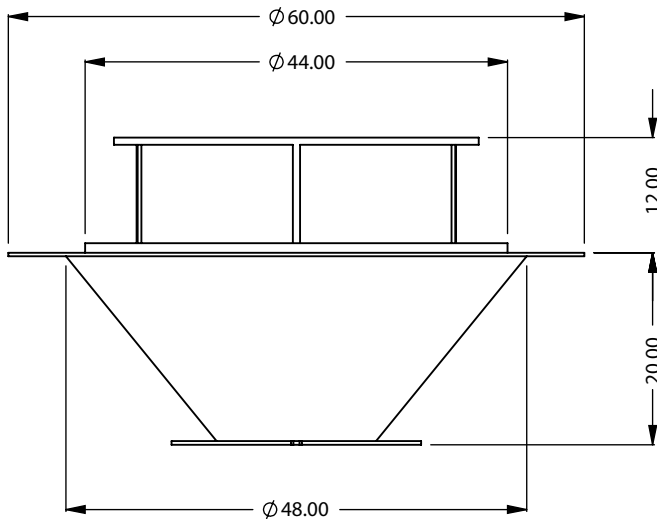
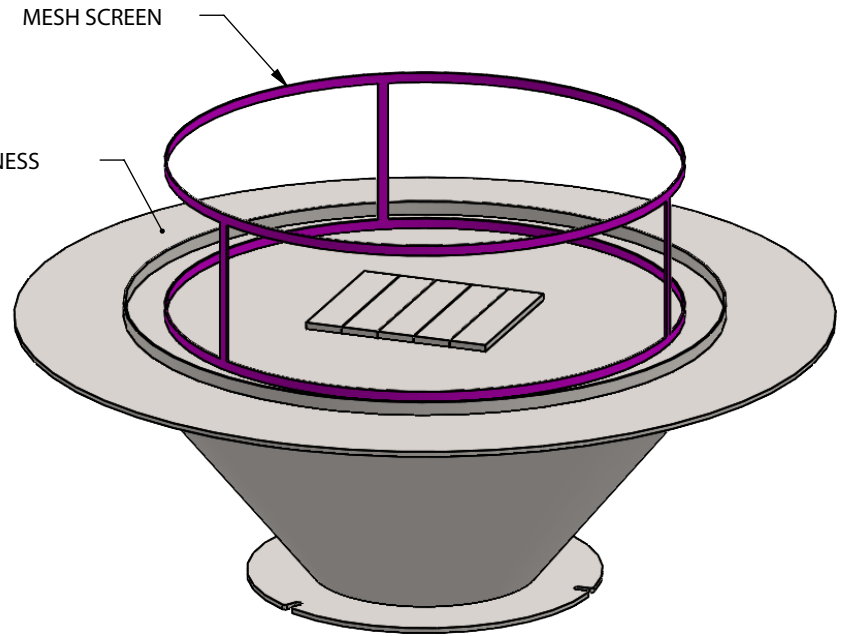
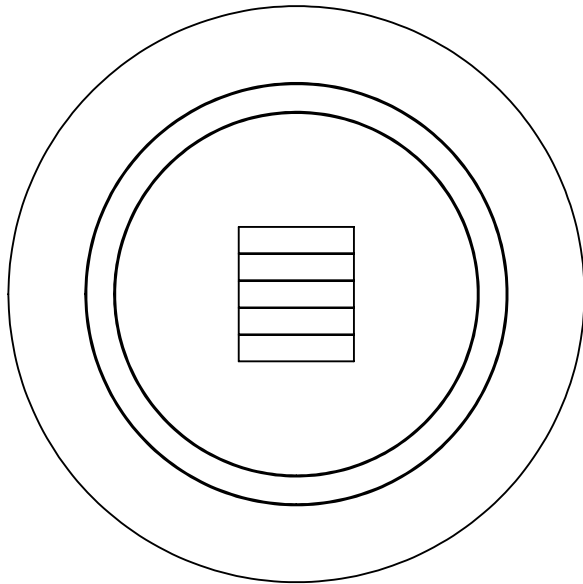

CFPO-RD-48-TB-DL-MS
 Round Firepit
Bottom Intake

**PRELIMINARY
 DRAWING ONLY**

EXAMPLE CONFIGURATION	UNLESS OTHERWISE SPECIFIED	DATE
MONTIGO COMMERCIAL FIREPLACES ARE CUSTOM BUILT FOR EACH PROJECT. THIS DRAWING IS FOR REFERENCE ONLY. FLUE AND AIR INTAKE SIZES ARE SUBJECT TO CHANGE DEPENDING ON VENT RUN.	DIMENSIONS ARE IN INCHES TOLERANCES: FRACTIONAL $\pm 1/8"$	4/25/2023

MONTIGO
 the art of **fireplaces**
 www.montigo.com

MONTIGO® CFPO-RD-48-TB-DL Firepit Round

TECHNICAL SPECIFICATION

This Montigo commercial firepit and its associated components are part of a custom engineered system. All systems are tested and certified to current ANSI Standards with CSA International US and Canada.

Please contact Montigo to confirm if your installation requirements are within the parameters of these standard specifications.

Unit should be located in an exterior, well-ventilated location. If located under a roof or overhang, limitations may apply (please verify). If located in an unprotected area, unit should be covered when not in use.

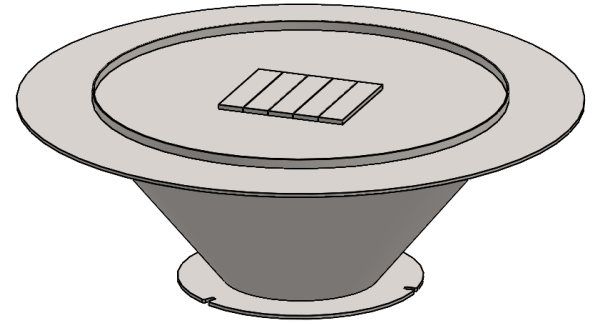

OVERVIEW

Burner Area: 48" Dia.

Integrated drink ledge

OPTIONS

Single or double protective glass†

Note: Unit dimensions will increase when single or double glass is requested. Please inquire as to actual size.

TYPICAL INTAKE

Intake Size: 17" sq.in. min.

Intake Location: Bottom

TYPICAL EXHAUST

Outdoor appliance, no dedicated vent

GAS

Rating Input: Estimated 90,000 BTU/hr

Minimum Inlet Pressure: 5.5" w.c. Natural Gas / 11" w.c. Propane

Gas System: ½" NPT bottom, Hot Surface Ignition, Smart Valve

Concealed modular burner with plume flame

CONSTRUCTION

Satin galvanized (black), delivered finished or can be clad; supplied locally by others

ELECTRICAL

Standalone NEMA weatherproof box with built-in on/off switch mounted within 50' -150' of firepit near 120 VAC 5 AMP exterior outlet

Box includes short whip and three prong plug

BURNER MEDIA

Glass media

Optional: Driftwood logs, speckled stones

TESTING STANDARDS

ANSI Z21.97-2017/CSA 2.41-2017

† May be available, please inquire on your specific project, waiver required

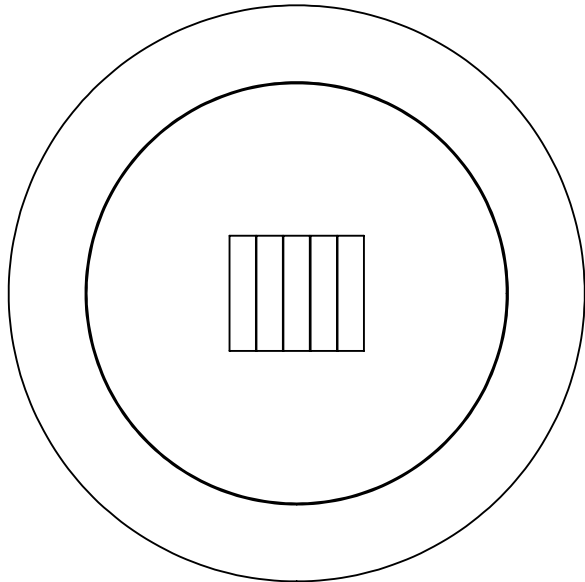

3/8" DRINK LEDGE THICKNESS

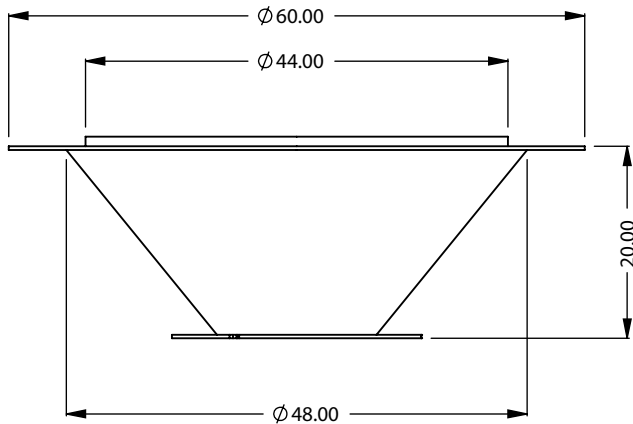
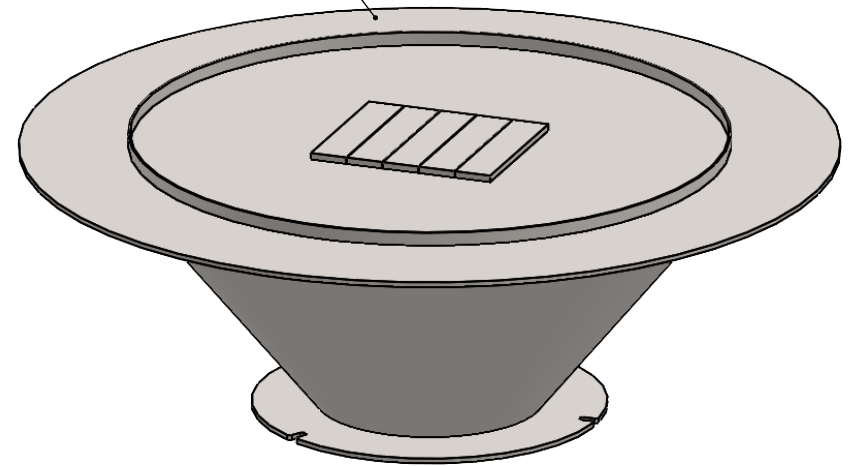

CFPO-RD-48-TB-DL
 Round Firepit
Bottom Intake

**PRELIMINARY
 DRAWING ONLY** 

EXAMPLE CONFIGURATION	UNLESS OTHERWISE SPECIFIED	DATE
MONTIGO COMMERCIAL FIREPLACES ARE CUSTOM BUILT FOR EACH PROJECT. THIS DRAWING IS FOR REFERENCE ONLY. FLUE AND AIR INTAKE SIZES ARE SUBJECT TO CHANGE DEPENDING ON VENT RUN.	DIMENSIONS ARE IN INCHES TOLERANCES: FRACTIONAL ± 1/8"	4/25/2023

MONTIGO
 the art of **fireplaces**
 www.montigo.com