

885 PROFLAME

USE AND INSTALLATION INSTRUCTIONS



Read the instructions before use. This control must be installed in accordance with the rules in force.

885 consists of two automatic shut-off valves and a modulating servo pressure regulator in series in the main gas path.

With reference to the schematic block in Fig. 1:

- FLI is the inlet filter.
- EV1 is the first automatic shut-off valve.
- EV2 is the second automatic shut-off valve.
- RP is a pressure regulator.
- MD is a pressure modulator device.
- FLO is the outlet filter (on request).
- PA is the pilot adjustment screw.
- FLP is the pilot filter.

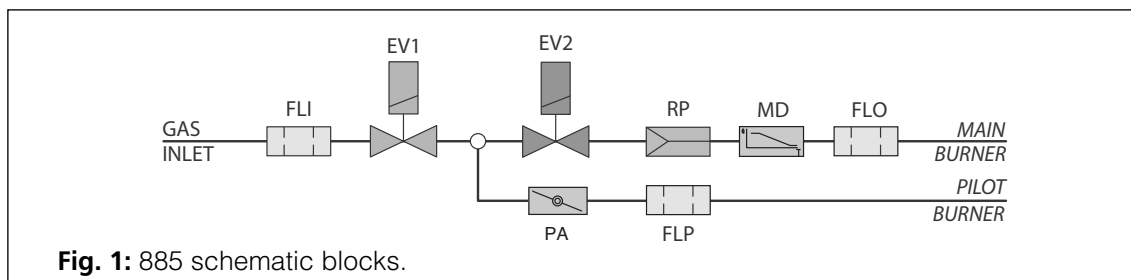

TECHNICAL DATA

Gas inlet and outlet connections	- 3/8" - 18 NPT ANSI B 1.20.1 - 5/8" - 18 SAE J512 - 9/16" - 24 UNEF ANSI B 1.1
Pilot outlet	7/16" - 24 UNS - 2B ANSI
Installation position	Upright, LTD horizontal (Never Upside down)
Gas families	Natural gas LNG ,LPG
Maximum gas inlet pressure	1/2 PSI
Outlet pressure setting range	LPG: 10" to 6.4" w.c. (SIT code 0.885.001) NG: 3.5" to 1.6" w.c. (SIT code 0.885.002)

MAIN FEATURES

- Aluminium alloy body
- Inline inlet and outlet
- Pilot outlet
- Inlet filter
- Inlet pressure test point
- Outlet pressure test point
- Two mounting through holes on the side
- Two mounting holes on the gas inlet and outlet

VALVE DESCRIPTION

- | | | | |
|----------|-------------------------------|-----------|---------------------------------|
| 1 | ON-OFF solenoid EV1 terminals | 7 | Pilot outlet |
| 2 | ON-OFF solenoid EV2 terminals | 8 | Gas inlet with protective seal |
| 3 | Inlet pressure test point | 9 | Gas outlet with protective seal |
| 4 | Outlet pressure test point | 10 | Ground connection |
| 5 | Pressure modulator device | 11 | Mounting holes |
| 6 | Pilot adjusting screw | | |

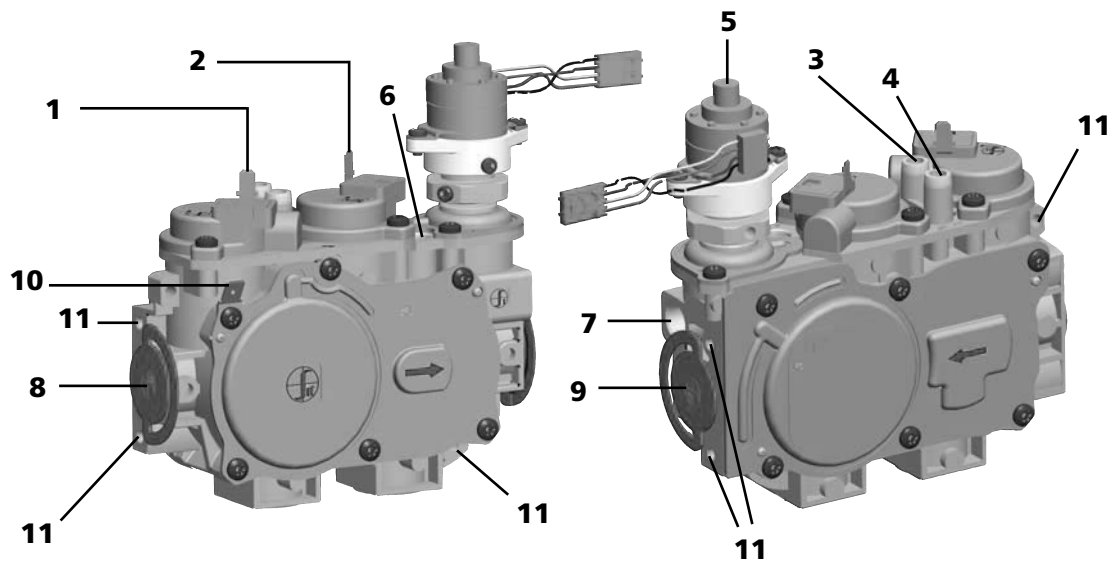

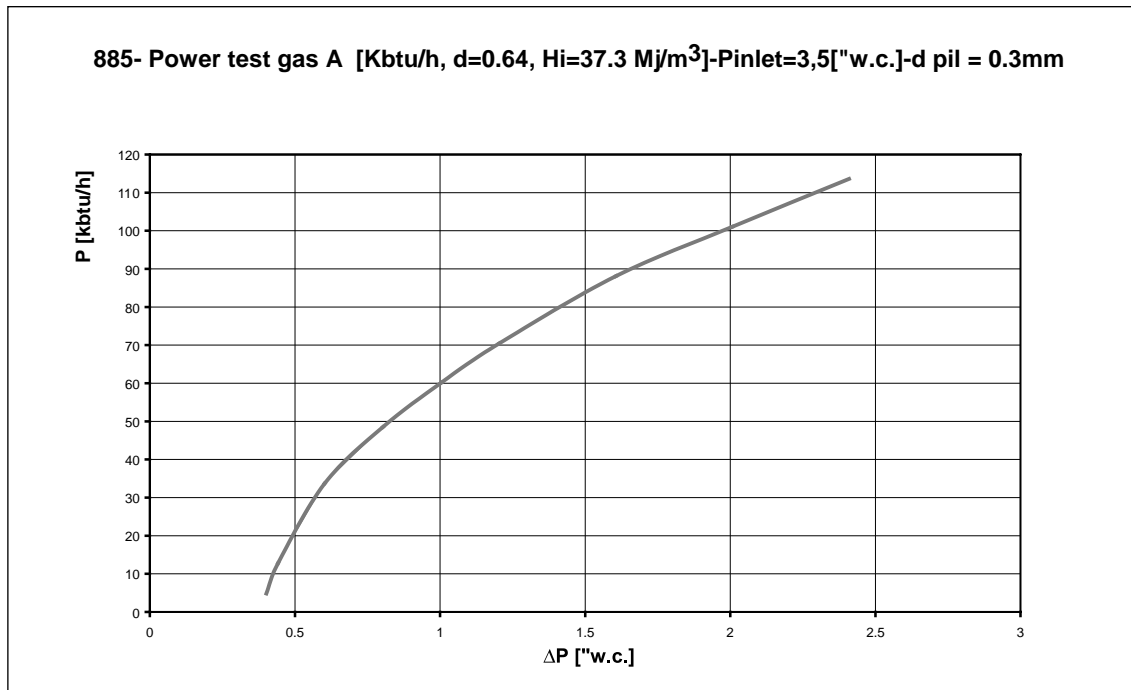
CAPACITY**FLOW RATE Q AS A FUNCTION OF PRESSURE DROP ΔP** **OPERATION**

885 Proflame has two automatic shut-off valves. When both of them are de-energised, it is only possible to measure the inlet pressure on the inlet pressure test point.

When the solenoid EV1 is energised the first gas valve opens. The pilot outlet is enabled.

Energising the second solenoid EV2, the second valve also opens and the gas flows through the main outlet.

It is possible to measure the outlet pressure on the outlet pressure test point.

The servo pressure regulator diaphragm system allows improved performance of outlet pressure regulation. The outlet pressure can be adjusted by a pressure modulator device.

STOP

Do not install, replace, or in any way modify the gas valve or the appliance, unless CERTIFIED and QUALIFIED as a Gas Appliance Service Technician on the appliance this valve is used on. READ AND FOLLOW ALL INSTRUCTIONS.

INSTALLATION

When installation of this product begins...

1. Read all of these instructions carefully. Failure to follow these instructions could damage the product or cause a dangerous condition.
2. Check the ratings given in the instructions and on the appliance to make certain that the control is suitable for your application.
3. All operations of installation, calibration, conversion and regulation must be undertaken exclusively by a qualified and certified Gas Appliance Service Technician following the instruction specified in this catalog and those in the instruction manual of the appliance in which

the valve is installed.

4. After installation is complete, verify that the appliance is operating as indicated in these instructions.

General recommendations

- Do not tamper with sealed parts
- Do not slacken assembly screws
- Do not remove labels
- Avoid blows (knocks, falls etc.)
- Only remove dust caps when installing
- Do not exceed recommended torque
- Ensure that the gas flows in the direction shown by the arrow on the valve body
- Use only the specified spanner grips when making the connections
- Do not immerse in water or subject the multifunctional gas control to temperatures exceeding 70°C
- Turn off gas supply before starting installation

WARNING



IF A SINGLE VALVE FALLS, DO NOT USE FOR PERFORMANCE AND SAFETY REASONS

WARNING



DO NOT SUBJECT THE VALVE TO BENDING IN EXCESS OF 310 LBF IN AND TORQUE IN EXCESS OF 220 LBF IN

WARNING

Oxygen Depletion Hazard. Can cause injury or death by asphyxiation.

Do not use valves for vented appliances on unvented or vent free appliances. Do not use valves for unvented or vent free appliances on vented appliances.

WARNING

Fire or Explosion Hazard. Can cause property damage, severe injury or death.

Follow these instructions completely.

1. Turn off gas supply at the appliance service valve before installation, and perform a Gas Leak Test after the installation is completed.
2. Always install the sediment trap in the gas supply line to prevent contamination of the gas control.



CAUTION

Electrical shock or equipment damage hazard.

Can shock individuals or short equipment circuitry.

Make sure to disconnect all electrical supplies before beginning the installation process.

IMPORTANT

- These gas controls are shipped with anti-contamination seals over inlets and outlets.
- Do not remove the seals until ready for connection to piping.
- Appliance manufacturer's instructions supercede any instructions listed in this instruction book.

INSTALL PIPING TO GAS VALVE

All piping must comply with local codes and ordinances or with the National Fuel Gas code (ANSI Z223.1 NFPA No. 54) whichever applies. Tubing installation must comply with approved standards and practices. Use appropriately sized fittings when connecting aluminum tubing to the pilot outlet.

1. Use new, clean and correctly reamed pipe free from burrs, chips, debris and any foreign matter. When tubing is used, make sure the ends are square and clean. All tubing bends must be smooth and without deformation.
2. Run pipe or tubing to the valve. If tubing is used, obtain a tube-to-pipe coupling to connect the tubing to the valve.
3. Install sediment trap (Drip Leg) in the supply line to the gas valve.

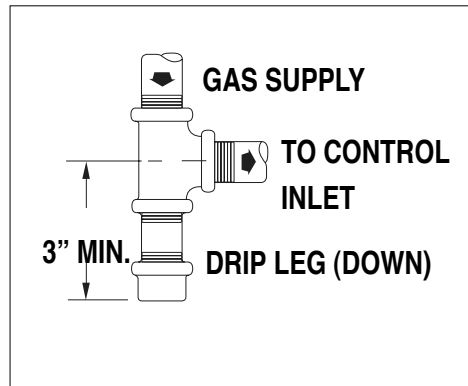

INSTALLING THE VALVE

1. Mount the valve in the desired position.
2. Mount the valve so the flow of gas is consistent with the gas flow arrows on the valve.
3. Apply a moderate amount of quality pipe compound (DO NOT USE TEFLON TAPE) to the pipe only, leaving two end threads bare. On LP installations, use compound that resists exposure to LP gas.
4. Remove seals over inlet and outlets if necessary.
5. Connect pipe to valve inlet and outlet. Place a 1" 1/16 wrench on valve as shown in Fig. 2.
6. Thread pipe into the valve until a gas tight seal is achieved. Typically, for NPT thread, penetration is usually no more than the diameter of the pipe or 2 and 1/4 turns thread. Valve distortion or mechanical failure can result if the pipe is inserted too deeply.
7. Connect pilot tubing to valve with appropriately sized fittings as shown in Fig. 3.
8. Confirm gas tight seals with gas leak test.

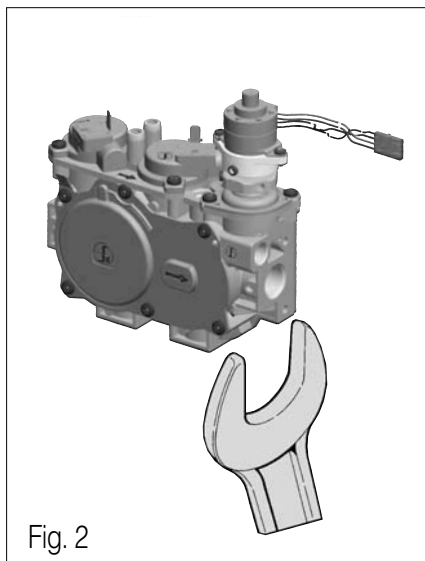

Fig. 2

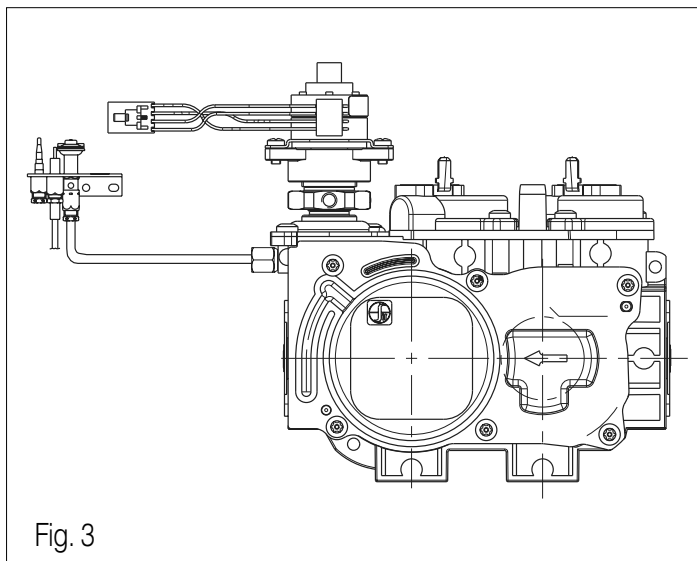

Fig. 3

FINAL CHECKS

WARNING:

Fire or Explosion hazard.

Can cause damage to property and severe injury or death.

The appliance where this combination gas control is installed, does not have a permanent pilot. It is equipped with an ignition device which automatically light the burner.

- Do not try to light the burner by hand.
- The appliance can turn on suddenly. Keep away from the main burner.

PERFORM GAS LEAK TEST

WARNING:

Stand away from the main burner while lighting.

Hidden gas leaks can cause flashbacks in the appliance area. Check for gas leaks with rich soap and water solution any time work is done on a gas system.

GAS LEAK TEST

- Using a solution of soapy water, paint the piping connections, which are upstream of the control. The presence of bubbles indicates a gas leak.
If a leak is detected, tighten the pipe connections and repeat leak test.
- Light the main burner.
- With the main burner in operation, paint all piping connections from the valve with a soap and water solution.
- If another leak is detected, tighten the connection.
- If after tightening the connections the leak is still present, replace the leaky part or valve. Shut off the main gas supply before attempting replacement of parts or the valve.
- Using the soap and water solution, test the pressure test ports to verify that no leak is present.
- If a leak is detected, tighten the screw and retest.
- If after tightening the pressure test port screw and the leak is still present, shut off main gas supply, then replace the valve.

Maintenance

This valve is not field serviceable. There are no replaceable parts. Do not disassemble, or attempt replacement of any parts on or in the valve. Improper adjustment or tampering with settings can result in severe injury or death.



SITGroup